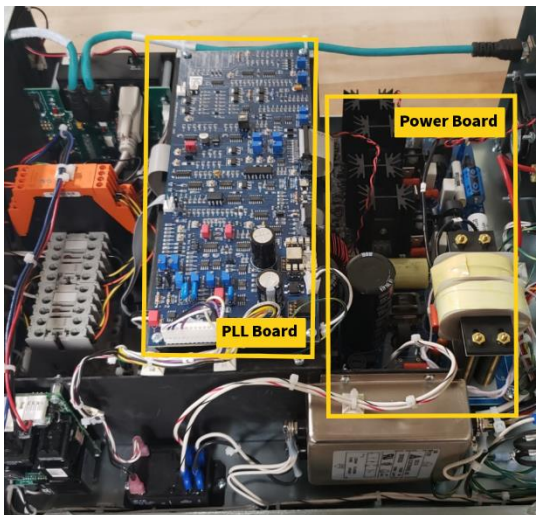

GXP/EP Preventive Maintenance Guide (1550EP, 2050EP, 3050EP, 4050EP)

Introduction: The GXP/EP model Ultrasonic Welder has sensitive electronic and mechanical hardware to provide a high level of accuracy during the ultrasonic welding process. Hardware exposed inside the press and power supply can become contaminated over time depending on environmental conditions.

Purpose: To provide instructions and procedures in order to maintain the equipment to keep it in top working order to provide years of reliable operation.

Terms and Definitions:

- **GXP:** The GXP is the ultrasonic generator. This control box provides the ultrasonic energy for welding and also contains the motion controls for the motor driven EP Press.
 - **Power Board:** The Power board is located inside the power supply and is mounted on the bottom of the chassis. This board is approximately 10" by 10". This board generates the electrical signal to the converter to vibrate the horn at the specific frequency.



- **PLL Board:** The PLL board is mounted on a bridge frame over top of the Power Board. This board is approximately 4" by 10". This board controls the running frequency of the Power Board and ensures the Ultrasonic frequency and amplitude are maintained.

- **HMI:** The HMI is the user interface or touch screen where the weld parameters are entered for the welding process.

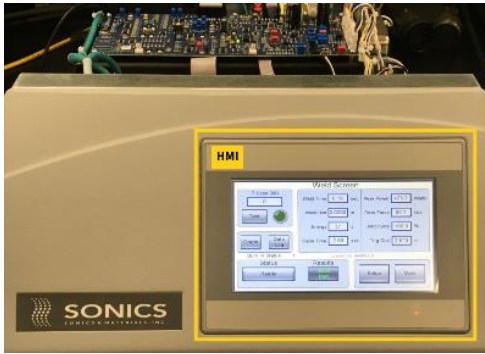

- **EP:** This is the Press actuator which contains the converter, booster and horn. This is where the parts are welded.
 - **Ball Screw:** In a typical welder there is an air cylinder to move the horn to the welding surface. The EP Press uses a precision ball screw to move the horn to the part which is driven by a stepper motor. The converter carriage is connected to a Ball Screw Nut that moves up and down as the screw turns.



- **Timing Belt:** The timing belt is the drive mechanism between the Stepper Motor and the Ball Screw.

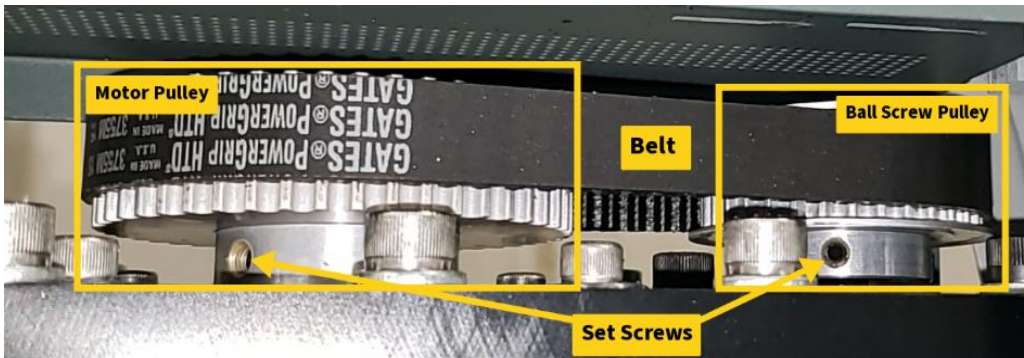

- **Pulleys:** There is a pulley on the motor and on the Ball Screw. These Pulleys transform the rotary motion of the stepper motor to the linear position of the carriage through the Ball Screw.

Preventive Maintenance:

CAUTION

Before performing any maintenance on the GXP EP system, remove electrical power and secure the line cord to prevent accidental power.

1. Clean and inspect the GXP power supply

- Remove the cover from the GXP power supply.
- Locate the Power Board and PLL Board.

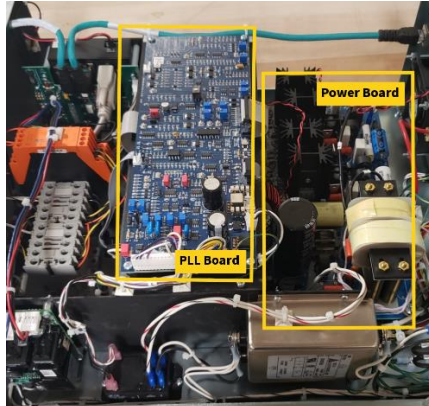

- Inspect the boards for dust build up as this can cause overheating.
- With compressed air, gently blow the dust from the power supply and boards.
- Use compressed air (not exceeding 30psig).
- Check the fan for dust buildup on the blades and clean as necessary.

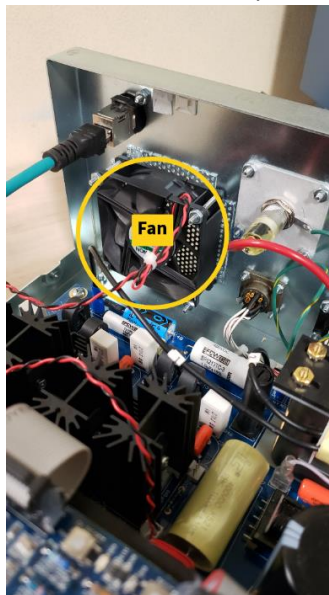

- Check for loose hardware and harness connections.
- From the rear of the HMI, use compressed air (not to exceed 30psig), to clean dust from inside and around the HMI.

2. Clean and inspect the EP Press Actuator

- Remove the side covers from the press.
- Remove dust buildup with compressed air (Not to exceed 30psig).
- Manually lower the horn to the full extent by turning the pulley on top of the motor.

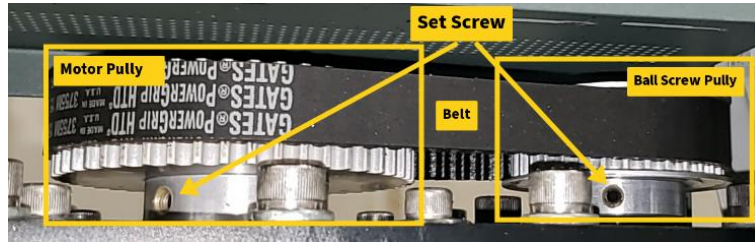

- This will expose the working length of the screw.

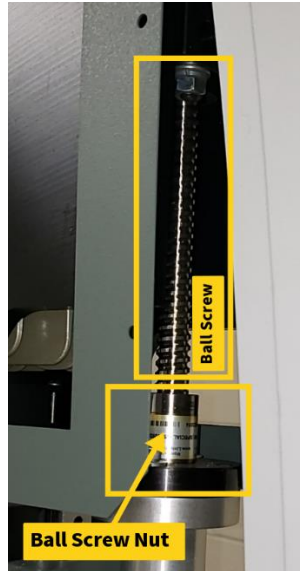

- With a clean rag, clean the exposed length of the ball screw rotating to expose all sides.
 - Closely inspect the grooves of the screw for dirt build up.
- When the ball screw is clean and dry, apply the recommended lubricant to the ball screw.
 - Nook brand E-900 Ball Screw Lubricant.



- Turn the motor pulley to expose the full circumference of the screw to the lube.
- With a clean rag, clean any over spray from internal surfaces.

- Locate the Load Cell Cord.



- This cord stretches and contracts every cycle.
 - Inspect for wear or breaks.
 - Replace if necessary (*do not repair, contact Sonics for further information*).
- Check the Pulley Set Screws to be sure they are tight.

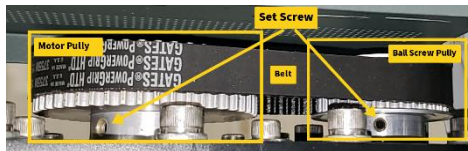

- Verify the set screws have not come loose.
- Check the belt tension on the Pulleys.
 - Push in on the belt between the pulleys with approximately 3 to 5 lbs, the belt should not move more than approximately 0.250"

3. Weld Stack – Converter, Booster & Horn

- Remove the Stack from the Press.

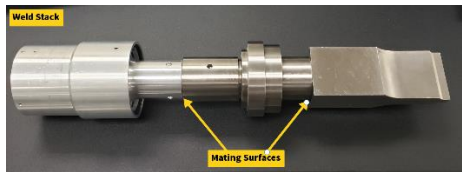

- Disassemble and remove studs.



- Clean each surface to ensure a smooth mating interface. Use a Scotch-Brite pad to clean the surfaces if necessary.

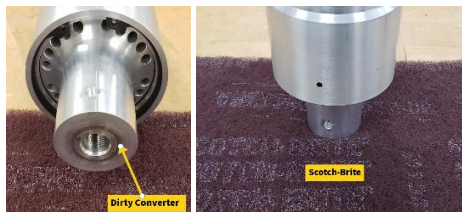

- Reassemble the stack and torque to proper specification. ½-20 thread torque is 60 ft-lbs.

4. Cables and Connections

- Inspect all connections between the GXP power supply and the EP press.



- Ensure there are no kinks, breaks or cuts in the cabling.
- Replace if necessary, (*do not repair, contact Sonics for further information*).
- Threaded connectors should be hand tight, re-tightened as required.
- Relieve stress on connection if necessary.
 - The cables should not be pulled from the GXP or the EP
- Reduce the distance between the GXP and the EP if there is excessive tension on the interconnecting cables

Reinstall all covers to the GXP Power Supply and the EP Press

5. Press Actuation – Dual Palm Buttons

- For this test, power the system on and enter the Run screen
- Press both palm buttons.
- Verify the press head actuates (moves toward the part).
- Immediately release the buttons before the horn reaches the part.
- Verify the Press head returns to the home position.
- Press one palm button and wait 1 second then press the second palm button.
- Verify the Press head does not actuate.
- Repeat the previous two steps in reverse order.

6. E-Stop (Emergency Stop)

- For this test, power the system on and enter the Run screen.
- Press both palm buttons.
- Verify the press head actuates.
- When the horn reaches the part, activate the E-Stop.
- Verify that the press head moves away from the part and stops.
- The press head will not move all the way to the home position until the E-Stop has been cleared and reset.