

more **Power**
Features

new POWER

Now available in:
3500 watts
4500 watts

new FEATURES

- Digital Amplitude Control
- Ultrasonic Horn/Stack
Frequency Display
- Good Part/Bad Part
Output Signal
- Digital Soft Start
Amplitude Ramp Control*
- Line Voltage Phase Angle
Regulation*

new MODELS

WELD BY:

digital time
- **Model GXT**

digital time and/
or constant energy
- **Model GXE**

digital time, constant
energy and/or distance
- **Model GXL**

**STANDARD
FEATURES INCLUDE:**

- Automatic Frequency Tuning
- Multiple Job Storage
- Digital Force Triggering
- Calibration Pulse Prior to
Every Weld Cycle
- Back-Lit LCD Display
- Ultrasonics Load
Meter Scale
- Upper and Lower Weld
Limit Settings
- Optional RS232 Printer
Output Port
- Optional PLC I/O
(Input/Output) Ports
- Soft Start Overload
Protection Circuitry
- Load Regulation Circuitry
- Distance Mode Settings in
English or Metric Units**

**Requires optional linear encoder



SONICS[®]
SONICS & MATERIALS, INC.

Model 1595 15 kHz ultrasonic plastics welding systems

Model 1595 Press



GX-Series High Profile Power Supply



Leaders in the field of ultrasonic plastics welding equipment and technology since 1969, Sonics & Materials offers its new line of **GX-Series** ultrasonic power supplies, combined with 15 kHz welders, for welding medium to large-sized parts at higher amplitudes.

The new GX-Series provides microprocessor control and consistent reliability for every application. Power supplies feature smart-logic, user-friendly keypad navigation. Line voltage phase angle regulation allows for single phase power requirement and promotes conservation of on-demand electrical energy.

POWER SUPPLIES

High Profile Chassis

3500 or 4500 Watts Power

Height: 11.00" (279.4 mm)

Width: 17.75" (450.8 mm)

Depth: 22.50" (571.5 mm)

Weight: 70 lbs. (31.8 kg)

for more information: 1-800-745-1105 www.sonics.com

Innovating
since

1969

dimensional data

All Dimensions: Inches (mm)

model 1595 features

- Single Piece Rigid Cast Aluminum Base and Column Hub
- Dual Column Low Friction Linear Bearings
- Direct In-Line Air Cylinder
- Motorized Actuator Head Up and Down Switches
- Motorized Actuator Head Up and Down Adjustment
- Front Panel Pneumatic Pressure and Speed Up and Down Controls
- Linear Encoder for Distance Welding (optional)

specifications, additional features and options

Dual Cycle Start Buttons	Standard
Non-Contact Cycle Start Buttons	Optional
Front Emergency Stop	Standard
Adjustable Positive Stop	Standard
Automation Limit Switches	Optional
360° Snap-In Stack Assembly	Standard
Stand Alone Column Hub	Optional
Extended Length Column	Optional
3.75" (95.3) Column Diameter	Standard
4" (101.6) Stroke Air Cylinder	Standard
Air Cylinder Bore Diameter	4" (101.6)
Clamping Force at 90 PSIG	1130 lbs. (5026n)
Input Voltage	220 VAC
Weight (1595)	280 lbs. / 127.0 kg

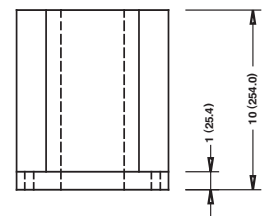
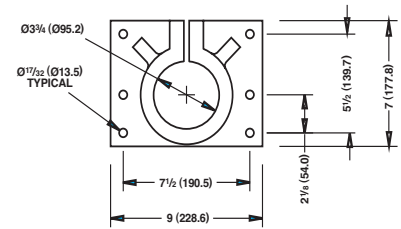
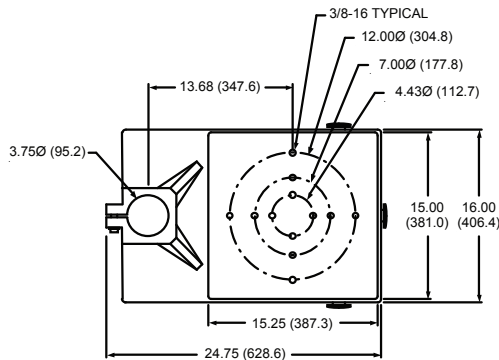
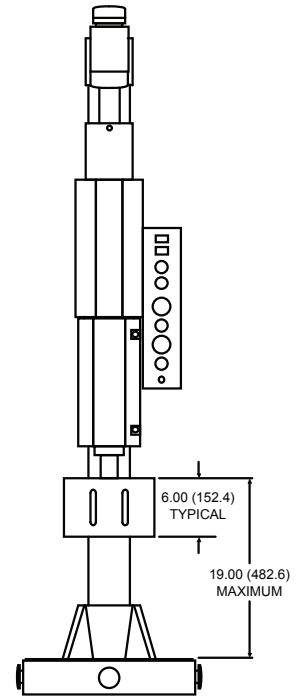
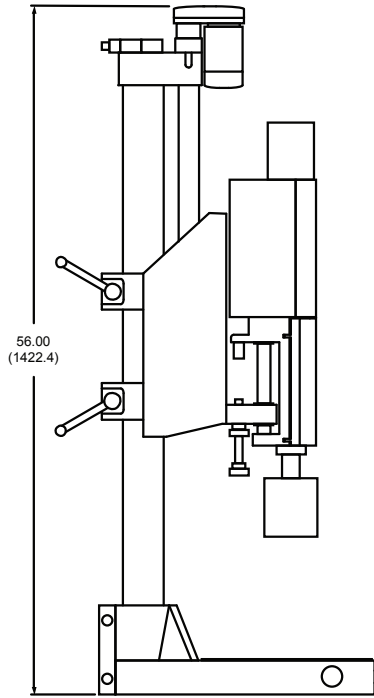

optional stand-alone hub