



SONICS[®]
SONICS & MATERIALS, INC.



Model ZM-30
30 kHz ultrasonic
zipper crushing module

Model ZM-30 30 kHz ultrasonic zipper crushing

Ultrasonic zipper crushing is a fast, effective way to enhance hermetic side seals on standup pouches

- Fast cycle times - Ultrasonic energy melts from the inside out so thick zippers are flattened more quickly than conventional thermal tools
- Energy efficient – Ultrasonic systems do not draw electricity between cycles
- Increase productivity – No warm up time required with ultrasonic systems
- Process control – Ultrasonic processes offer programmable limits to ensure repeatability

SonicsEdge:

- Compact design for integration into tight spaces
- Light weight makes it suitable for continuous movement applications
- Up to 200 lbs of clamp force for fast cycle times
- Kit generator enables process control via existing PLC and HMI
- Positive stop provides repeatable crush depth and prevents over crushing
- Remote pneumatic controls for simple adjustments while in operation
- 30 kHz technology delivers high power and silent operation



Model H530T-1
power supply

dimensional data

All Dimensions: Inches (mm)

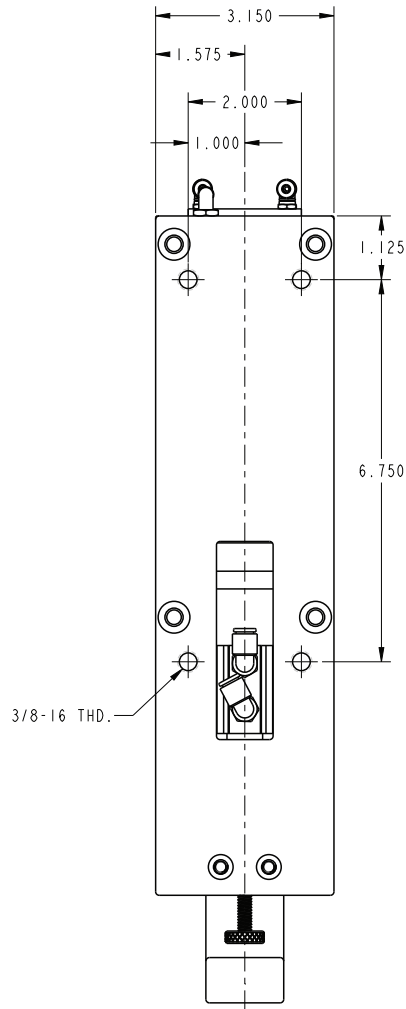
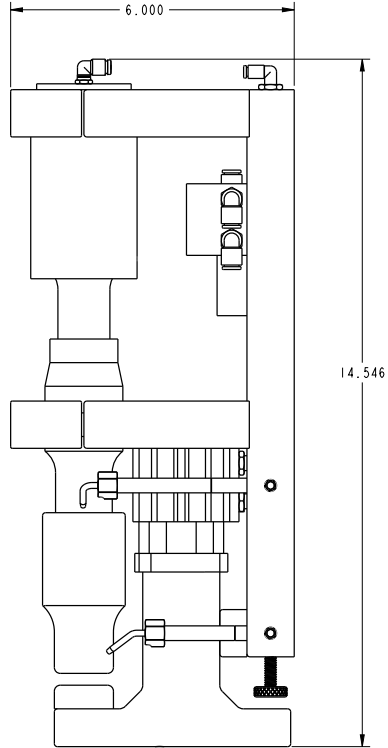

DB9 FUNCTIONS

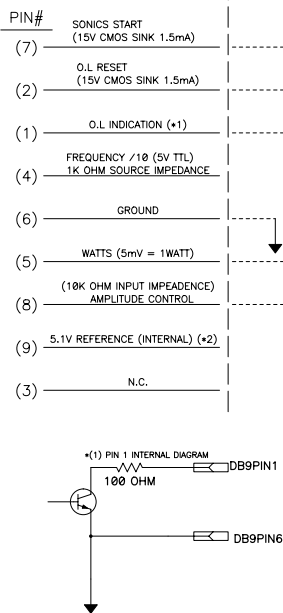

CUSTOMER I/O CONNECTIONS

