

*Models*  
*2050 / 2055*  
*Presses*

I N S T R U C T I O N M A N U A L



Sonics & Materials, Inc.

# WARNING

---



## ***SAFETY PRECAUTIONS READ BEFORE INSTALLING OR USING THE EQUIPMENT***

Our systems have been designed to assure maximum operator safety. However, no design can completely protect against improper usage. For maximum safety and equipment protection, observe the following warnings at all times and read all applicable instruction manuals carefully before you attempt to operate any equipment.

- The equipment has safety devices that require both hands to be on the palm buttons until the horn contacts the work piece. Do not defeat or modify these safety devices.
- Do not use with foot switch or other means of actuation unless alternate means of pinch-point protection is provided.
- High voltage is present in the equipment. Disconnect plug before removing cover or servicing.
- Make sure equipment is properly grounded with a 3-prong plug. Before plugging in equipment, test outlet for proper earth grounding.
- High voltage potential may be present in the converter as a result of temperature changes. Do not touch the converter contact unless you first short both pins or the button to the converter case with an insulated tool.
- Never squeeze or grab a vibrating horn.
- Do not modify horn configurations.
- 20 kHz, 30 kHz and 40 kHz ultrasonic welders operate above normal audibility for most people. Ear protection is recommended.
- Do not affix any device to any portion of the horn.

## **Sonics & Materials, Inc.**

### **Corporate Headquarters**

53 Church Hill Road • Newtown, CT 06470 USA  
203.270.4600 • 800.745.1105 • 203.270.4610 fax  
www.sonics.com • info@sonics.com

### **European Office**

13, Rue Pre-de-la-Fontaine • CH - 1217 Meryin/Satigny, Switzerland  
(41) (0) 22/364 1520 • (41) (0) 22/364 2161 fax  
europe@sonicsandmaterials.ch

Information contained in this manual is subject to change without notice. Sonics & Materials, Inc. is not responsible for any typographic errors.

# TABLE OF CONTENTS

---

<b>IMPORTANT SERVICE LITERATURE</b> .....	3
Manual Change Information .....	3
<b>UNPACKING AND INSPECTION</b> .....	4
Visible Loss or Damage .....	4
Concealed Loss or Damage .....	4
<b>INTRODUCTION</b> .....	5
<b>OVERVIEW OF ULTRASONIC PLASTICS ASSEMBLY</b> .....	5
What is Ultrasonics? .....	5
Principal of Ultrasonic Assembly .....	5
Ultrasonic Assembly Systems .....	5
<b>GLOSSARY OF ULTRASONIC TERMS</b> .....	7
<b>INSTALLATION</b> .....	8
Electrical Power .....	8
Air Supply .....	8
Setting Up .....	8
Connections .....	9
Options .....	10
<b>OPERATING PROCEDURES</b> .....	11
Control Panel (2050 Press) .....	11
Controls (2055 Press) .....	12
<b>INITIAL EQUIPMENT SETUP</b> .....	14
Assembling and Mounting Converter, Booster and Horn .....	14
Horn and Fixture Alignment .....	16
Positive Stop Adjustment .....	17
<b>OPERATION</b> .....	18
Actuation .....	18
Emergency Stop .....	18
<b>FINE ADJUSTMENTS</b> .....	19
Booster Selection .....	19
Pressure .....	19
Re-Establishing Proper Booster/Horn Interfaces .....	20
<b>MAINTENANCE</b> .....	21
Repairs / Service .....	21
Draining Air Filter Bowl .....	21
Cover Removal .....	22
Pressure Switch Adjustment .....	24
<b>WARRANTY</b> .....	26
Limitation of Warranty .....	26
<b>APPENDIX</b> .....	28



# IMPORTANT SERVICE LITERATURE

---



**NOTE:** Please read carefully before operating the equipment, then forward to your service department.

The system supplied with this instruction manual is constructed of the finest material and the workmanship meets the highest manufacturing standards. It has been thoroughly tested and inspected before leaving the factory and when used in accordance with the procedures outlined in this manual, will provide you with many years of safe and dependable service.

## **MANUAL CHANGE INFORMATION**

We continually strive to be at the forefront of the latest electronic developments by adding circuit and component improvements to our equipment as soon as they are developed and tested.

Sometimes, due to printing and shipping requirements, we cannot incorporate these changes immediately into printed manuals. Hence, your manual may contain new change information. Change information, if any, is located in the Appendix.

We reserve the right to make any changes in the design or construction of our equipment at any time, without incurring any obligation to make any change whatsoever in units previously delivered.

The technical data and schematics in the manual are for informational purposes only and may not reflect the current configuration being shipped from our factory. Upon formal request, complete and up-to-date information can be provided from the factory free of charge.



# UNPACKING AND INSPECTION



**NOTE:** We recommend keeping all carton(s) and packing material in case it might be necessary to move the equipment, or to ship it for repair.

Before unpacking the equipment, check the shipping carton for any visible damage. If you see any, be sure to follow the procedures described below under “Visible Loss or Damage.” Otherwise, proceed to remove the equipment from the carton. Before disposing of any packing material, check it carefully for small parts. Then perform a visual inspection of the equipment to detect any evidence of damage which might have occurred during shipment. Check the following:

1. all components against the enclosed packing list,
2. all module plug-in units,
3. all wire plug-in connections.

The equipment was carefully packed and thoroughly inspected before leaving our factory. All units are tested and checked for problems prior to shipping. It is asked that when a problem does occur that all parts and components be inspected for damage (especially when the unit is not in working order when received). Responsibility for safe delivery was assumed by the carrier upon acceptance of the shipment. Claims for loss of damage sustained in transit must therefore be made upon the carrier, as follows:

## **VISIBLE LOSS OR DAMAGE**

Any external evidence of loss or damage must be noted on the freight bill or express receipt, and signed by the carrier’s agent. Failure to adequately describe such external evidence of loss or damage may result in the carrier’s refusal to honor a damage claim. The form required to file such a claim will be supplied by the carrier.

## **CONCEALED LOSS OR DAMAGE**

Concealed loss or damage means loss or damage which does not become apparent until the merchandise has been unpacked. The contents might have been damaged in transit due to rough handling even though the container may not show external damage. When the damage is discovered upon unpacking, make a written request for inspection by the carrier’s agent within 48 hours of the delivery date. Then file a claim with the carrier since such damage is the carrier’s responsibility. The form required to file such a claim will be supplied by the carrier. Do not destroy packing materials, or move material from one location to another before the carrier makes their inspection.

If the system or any unit is damaged, notify “Sonics.” “Sonics” will arrange for repair or replacement of damaged equipment without waiting for the claim against the carrier to be settled, provided a new purchase order is issued to cover the repair or replacement costs. Should any damage, shortage or discrepancy exist, please notify us immediately.

---

# INTRODUCTION

---

The models 2050 and 2055 presses are 20 kHz precision benchtop pneumatic actuators/presses used for ultrasonic plastics assembly. The 2050 and 2055 presses can be supplied with the following GX-Series power supplies:

- GXT . . . . .Weld by digital time
- GXE . . . . .Weld by digital time and/or constant energy
- GXL . . . . .Weld by digital time, constant energy and/or distance\*

*\*Available with Model 2050 press only.*

Both presses are also compatible with E and F Series power supplies.

---

# OVERVIEW OF ULTRASONIC PLASTICS ASSEMBLY

---

## **WHAT IS ULTRASONICS?**

Ultrasonics refers to vibrational waves with a frequency above the human audible range which is usually above 18,000 cycles per second (Hz).

## **PRINCIPLE OF ULTRASONIC ASSEMBLY**

The basic principle of ultrasonic assembly involves conversion of high frequency electrical energy to high frequency mechanical energy in the form of reciprocating vertical motion which, when applied to a thermoplastic, generates frictional heat at the plastic/plastic or plastic/metal interface. In ultrasonic welding, this frictional heat melts the plastic, allowing the two surfaces to fuse together; in ultrasonic staking or insertion, the controlled flow of molten plastic is used to capture or lock another material in place (staking) or encapsulate a metal insert (insertion).

## **ULTRASONIC ASSEMBLY SYSTEMS**

“Sonics” ultrasonic assembly systems are generally composed of the following major elements: a power supply, converter, booster, horn, pneumatic press/actuator and holding fixture, as detailed in the diagram on the next page. A review of this diagram will help you understand the basic elements involved in the assembly process and their relation to each other.

**“SONICS” ULTRASONIC ASSEMBLY SYSTEMS**

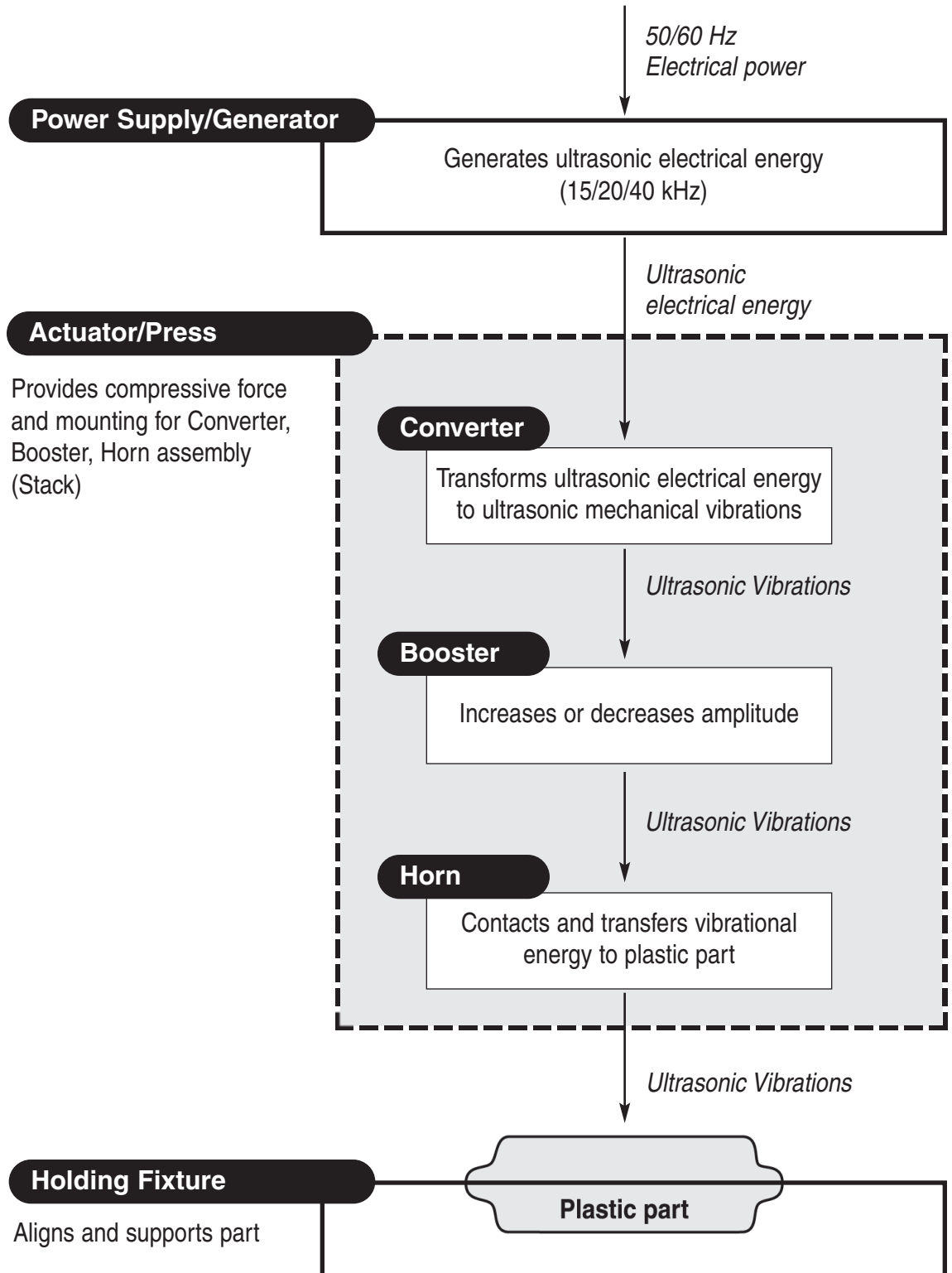

# GLOSSARY OF ULTRASONIC TERMS

**POWER SUPPLY/GENERATOR** – The solid state power supply converts standard 50/60 Hz electrical power to 15,000 Hz, 20,000 Hz, 30,000 Hz or 40,000 Hz (15/20/30/40 kHz) electrical energy (depending on frequency of model purchased).

**ACTUATOR/PRESS** – The pneumatic actuator provides compressive force and mounting for the converter, booster, and horn assembly. The benchtop press consists of a base assembly, column and actuator (head).

**CONVERTER** – The converter changes the high frequency electrical energy supplied by the power supply to high frequency mechanical vibrations.

**BOOSTER** – Successful ultrasonic welding often depends on having the right amplitude at the horn face. Often it is not possible to design a horn which has both the necessary shape and required gain (ratios of input amplitude to output amplitude). Therefore, a booster is placed between the converter and the horn to either increase or decrease the amplitude of the horn. In addition to changing/maintaining the amplitude, the booster provides support and alignment in the welding system. (See page 19 for booster selection.)

**HORN** – The horn is a tuned component of the system which comes in contact with the parts to be assembled. The horn 1) transfers the ultrasonic vibrations produced from the converter to the parts being welded, and 2) applies necessary force to the assembly while the material resolidifies.

**HOLDING FIXTURE** – The holding fixture or nest assures proper alignment and support of the parts being assembled.



MODEL 2050



MODEL 2055

# INSTALLATION

## ELECTRICAL POWER

The press is powered by the power supply. Consult your power supply instruction manual to determine power specifications.

## AIR SUPPLY

The press requires a source of dry, filtered (5 micron), oil-free, compressed air capable of supplying a constant line pressure of 85 psig. (586 kPa / 6 bar) at a minimum capacity of 2 CFM.



## WARNING

*Do not connect the press to an air source supplied by a compressor lubricated with synthetic oils or oils containing phosphate esters or chlorinated hydrocarbons. This type of lubricant may cause the air filter to malfunction, and the plastic bowl to rupture.*



**NOTE:** *If the power supply is to be run continuously, air cooling of the converter and horn is required. Use clean, dry compressed air filtered down to 5 microns (supplied to converter fitting).*

## SETTING UP

The press should be installed in a clear, uncluttered location that is free from excessive dirt, dust, corrosive fumes, and temperature and humidity extremes. The selected installation site should be near the electrical power and air supply sources and away from any equipment that generates abnormally high electrical transients. Observe the following additional instructions when installing the press:

- The press should be placed on a sturdy, level table or bench capable of supporting a minimum of 500 pounds (227 kg).
- Allow at least 6 inches (152.4mm) at the rear of the press for cable connections.

## KEY COMPONENTS

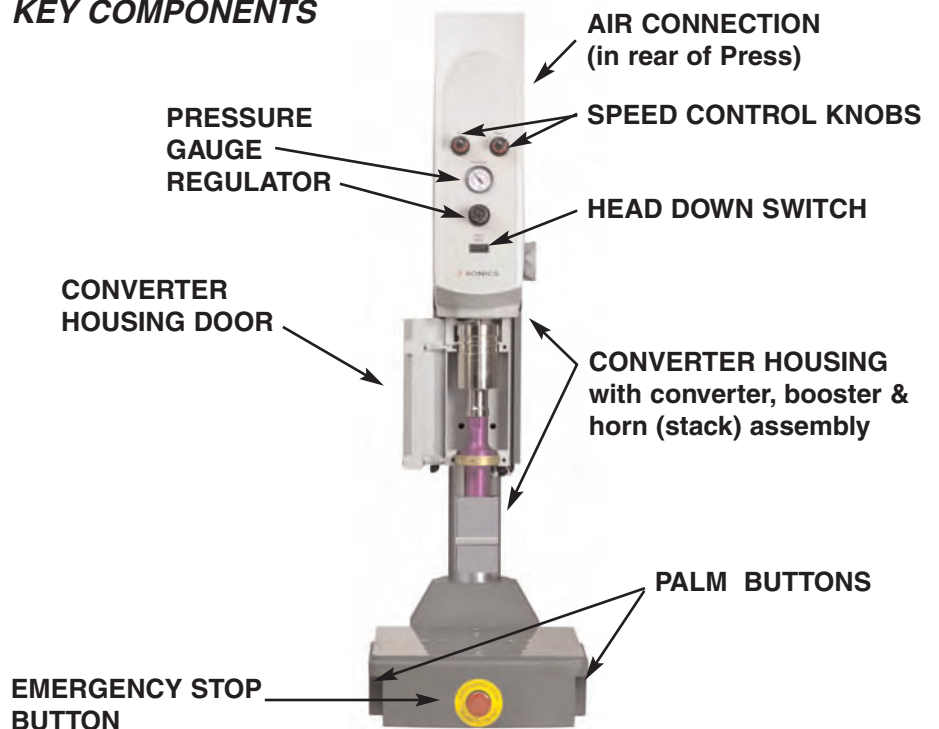



**NOTE:** Do not strain or kink the cables. When going around corners, allow as wide a bend as possible. Do not run the cables parallel to any power line within a distance of less than 1 foot (304.8mm).

## CONNECTIONS

When making the initial connections, make sure all electrical power is disconnected.

1. Connect the air supply source to the press air connection located at the rear of the press head, using a hose having a minimum inside diameter of 1/8 inch (3 mm).

A 1/4 NPT threaded female elbow connector is provided to attach your air line service. Connectors are typically an instant (push-to-connect) plastic tube fitting or a male sleeve lock type quick connect fitting.

### MODEL 2050

CONNECTOR

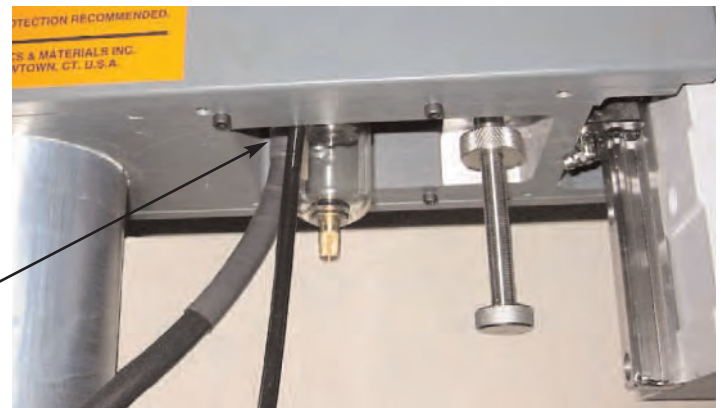

### MODEL 2055

AIR  
CONNECTOR  
(IN REAR)



2. Connect the RF and base (actuating) cables of the press to the power supply. (Consult your power supply instruction manual for details.)
3. Check with your electrician if you have any wiring questions.



**SONICS** .....

## ***OPTIONS***

A Linear Encoder is available as an option on Model 2050 only. The Linear Encoder allows distance-controlled welding in incremental and absolute modes.

The Linear Encoder is supplied with a 9-pin male connector that connects to a matching 9-pin female connector on the FDL power supply (factory installed).

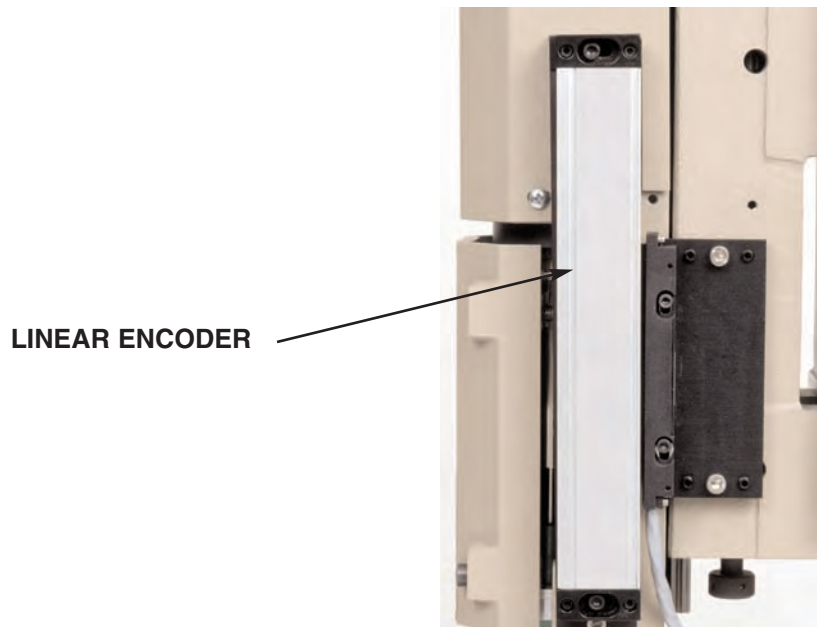

# OPERATING PROCEDURES

## CONTROL PANEL (2050 PRESS)

Located above the converter housing on the 2050 press are the following controls:

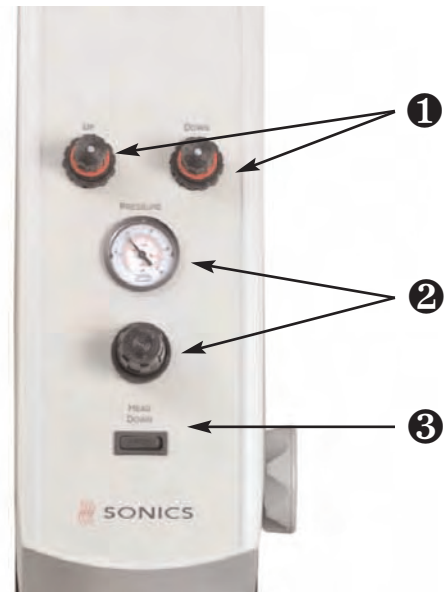

### WARNING

*Excessive velocity may be unnecessary and harmful to the system.*

1. **SPEED CONTROL** knobs allow regulation of the velocity at which the horn descends and returns (stroke speed).

These controls are factory adjusted for average operating conditions. When minor adjustments are necessary, be sure to adjust in small degrees.

Pull the red ring out to release and push in to lock setting.

The left knob, labeled "UP," controls the return speed - turn the knob clockwise to slow the speed, counterclockwise to increase speed.

The right knob, labeled "DOWN," controls the descending speed – turn the knob clockwise to slow the speed, counterclockwise to increase speed.

2. **PRESSURE REGULATOR** with corresponding gauge that allows regulation of the (air) pressure with which the horn contacts the part(s). Pull the knob to make adjustments, and then push in to lock setting when desired pressure is displayed on the gauge. Once pulled, turning the knob clockwise increases pressure, and turning it counterclockwise decreases pressure.
3. **HEAD DOWN** switch when depressed, allows the head to move down under gauge pressure. (For set up only – this action does not cause ultrasonics to be activated.)

## ***CONTROLS (2055 PRESS)***

Located at the top rear of the 2055 press are the following controls:

1. **PRESSURE REGULATOR** with corresponding gauge that allows regulation of the (air) pressure with which the horn contacts the part(s). Pull the knob to make adjustments, and then push in to lock setting when desired pressure is displayed on the gauge. Once pulled, turning the knob clockwise increases pressure, and turning it counterclockwise decreases pressure.

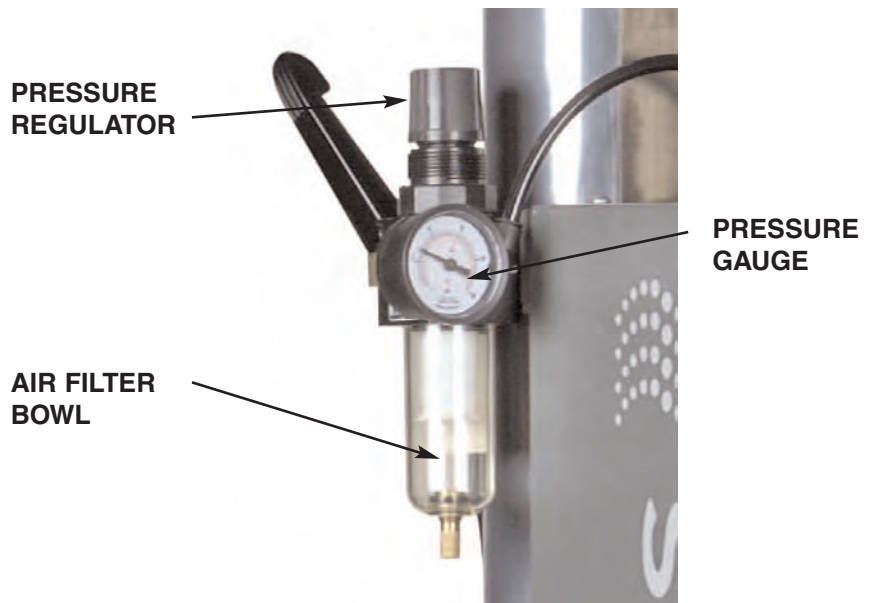



## WARNING

*Excessive velocity may be unnecessary and harmful to the system.*

## 2. SPEED CONTROLS

The velocity at which the horn descends and returns can be adjusted via the two small threaded screws located at the top of the press as shown below. These controls are factory adjusted for average operating conditions. If a minor adjustment is necessary, adjust in small degrees.

Turn the Descend Speed Control screw clockwise to slow the descend speed, counterclockwise to increase the speed. Turn the Return Speed Control screw clockwise to slow the return speed, counterclockwise to increase speed.

DESCEND  
SPEED  
CONTROL

RETURN  
SPEED  
CONTROL

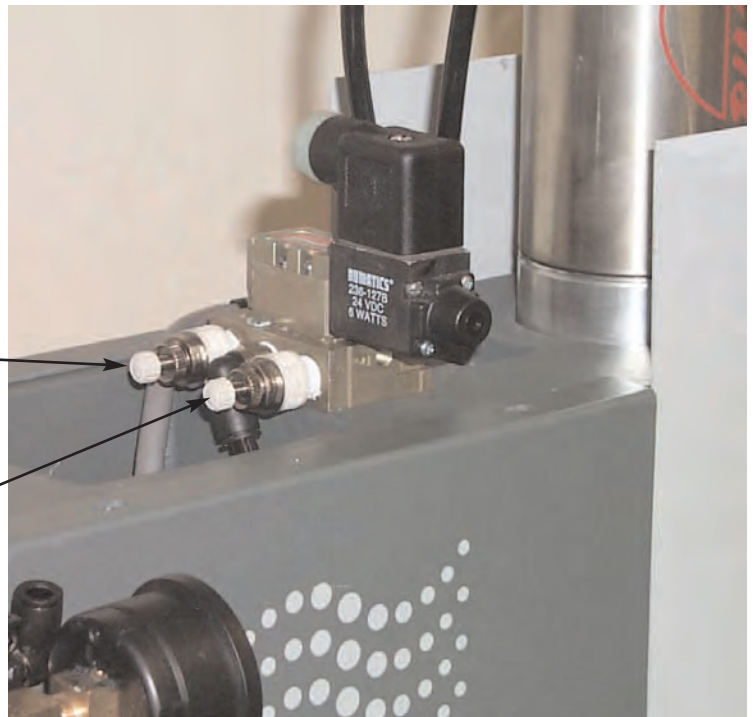

# INITIAL EQUIPMENT SETUP



## WARNING

*Never tighten the horn to the booster using the housing door as the upper wrench as this may cause damage to the booster and/or converter.*

## ASSEMBLING AND MOUNTING CONVERTER, BOOSTER, AND HORN

If the converter, booster, and horn are not already assembled, follow these instructions:

1. Clean the mating surfaces of the converter and booster, as well as the threaded stud and hole. Check that the stud is tight (see recommended torque requirements on page 15).
2. Hand assemble the converter and booster together. Using spanner wrenches as shown below, tighten until snug. Then, using a torque wrench, tighten to 25-35 foot-lbs. (34-47 newton-meters).

**Do not force or overtighten.**



3. Clean the mating surfaces of the booster and horn, as well as the threaded stud and hole. Check that the stud is tight. (See recommended torque requirements on next page.)

4. Hand assemble the horn to the booster. Using a spanner and an open-ended wrench as shown below, tighten securely. Then, using a torque wrench, tighten to 25-35 foot-lbs. (34-47 newton-meters).

**Do not overtighten.**



**SONICS** .....



**NOTE:** When performing any of the operations described on this page and pages 16-17, DO NOT turn on the power supply.

- Using the 3/16" (4.7 mm) T-handle wrench provided, loosen (turn counterclockwise) the two cap screws on the hinged converter housing and open the door.
- Place the converter / booster / horn assembly (stack) in the housing with the horn facing down. Fit the male brass button on the top of the converter into the female brass fitting in the bottom of the contact block assembly housing, and gently push the assembly up and in so that the booster mounting ring rests on the lower support ridge.

**CONVERTER / BOOSTER / HORN ASSEMBLY**

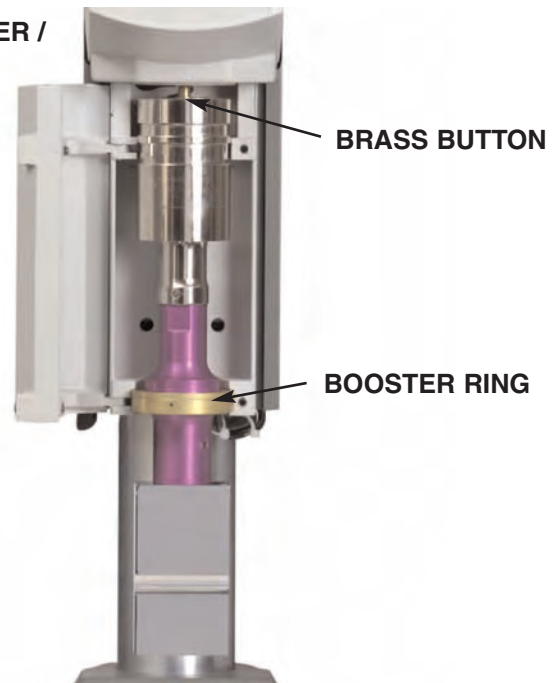

**WARNING**

Never tighten the horn to the booster using the housing door as the upper wrench as this may cause damage to the booster and/or converter.

- Close the converter housing door and tighten (turn clockwise) the two socket head cap screws until they are snug. Do not tighten the horn to the booster using the door as a clamp. Hand-forcing the horn on and off in this manner can twist wires in the converter and cause a failure. If the horn is not correctly oriented to the part, re-position the stack assembly by loosening the converter housing cover and rotating the stack.



**NOTE:** If you do not close the housing door once the assembly is in place, the assembly can fall out.

**RECOMMENDED TORQUE REQUIREMENTS**

Component	Foot-Lbs.	Newton-Meters
Converter / Booster	25 - 35	34-47
Booster / Horn	25 - 35	34-47
Stud	45	61
Tips	25 - 35	34-47



## WARNING

*Support the head before releasing the column clamps so that it cannot crash down or fly up. Ignoring this warning might result in injury and/or damage to the equipment and part being welded.*

## HORN AND FIXTURE ALIGNMENT

For maximum productivity, the clearance between the horn and the part should be at a minimum. However, adequate clearance should be provided to enable easy loading and unloading of the part from the holding fixture. The maximum stroke distance is 4" (101.6 mm). Ensure that the horn does not contact the part when the head is close to the limit of its down travel distance. Otherwise, the horn may not have sufficient distance to travel downwards to achieve a full depth of weld. Set welding height as follows:

First, position the holding fixture loosely on the machine base using 3/8-16 screws. Then, place the part to be welded in the fixture.

1. Prepare to loosen the column clamps, but be sure to hold onto the head assembly firmly as it can move rapidly up or down with heavy tooling once the clamps are released. While holding the head assembly, loosen the two column clamps (counterclockwise) and move the head up or down as required. Then tighten the column clamps.
2. Using the PRESSURE REGULATOR (turn counterclockwise) and corresponding gauge, set the air pressure to zero.
3. Loosen the column clamps once again and manually lower the head until the horn contacts the part. Tighten the clamps.
4. Loosen the cap screws on the converter housing door and gently rotate the head and horn as required to ensure proper horn-to-part alignment.

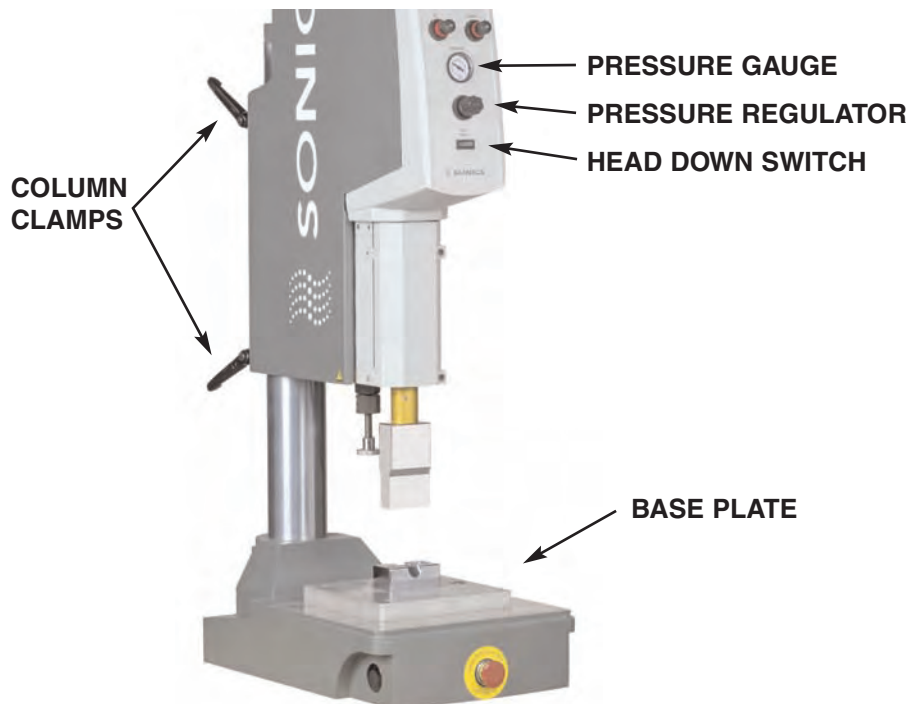

5. Lock the two column clamps, tighten the converter housing door screws, and then tighten the fixture on the base plate.
6. Check for proper mating of fixture, parts, and horn. If the horn and part are not in parallel contact, shim the fixture or adjust leveling screws as required.
7. Set the PRESSURE regulator to a reading of 20 psig (140 kPa/1.4 bar) on the pressure gauge. (Turn the PRESSURE knob clockwise.)
8. To check that the horn and parts are properly aligned, the horn needs to be lowered. Read through the Operation instructions on page 18, and then proceed to lower the horn as detailed. If the horn and parts are not sufficiently aligned, then repeat steps 4 through 8. However, if you are working with small, delicate parts, then fine adjustments can be made using the positive stop adjustment knob as explained below.



**NOTE:** For maximum safety and productivity, adjust the clearance between the horn and the part to a minimum that will still allow ease of loading and unloading.

### **POSITIVE STOP ADJUSTMENT**

The positive stop is set to limit the downward travel of the horn to approximately 75%. Readjustments may be required. Coarse adjustment of the clearance between the face of the horn and part should be made using the elevation control. Fine adjustment should be made using the positive stop.



The positive stop adjustment knob is located offset from the converter housing. Turning the knob clockwise will decrease downward travel distance. Turning the knob counterclockwise will increase the downward travel distance. Rotate the knurled thumbscrew to lock and unlock the positive stop.

A different positive stop is available for oversize horns. Contact factory for details.

# OPERATION

---



## WARNING

*The equipment has safety devices that require both hands to be on the palm buttons until the horn contacts the workpiece. **Do not defeat or modify these safety devices.***



**NOTE:** *Power supply cannot be shut off once the weld cycle has started. Termination of cycle can only be achieved by using the EMERGENCY STOP button.*



## WARNING

*Do not use with a footswitch unless alternate means of pinch-point protection is provided.*

## ACTUATION

Each 2050 and 2055 press is equipped with two maintained anti-repeat (non-tie-down) palm buttons, one located on the left and one on the right side of the base of the press. Both palm buttons must be pressed simultaneously to activate the press to cycle the welder. To operate the press, follow these simple steps:

1. Depress both black palm buttons simultaneously.
2. Once the horn comes in contact with the part, the pressure switch closes and the ultrasonics are activated, release the palm buttons. If you release the buttons before contact is made, the head will immediately return to its “home” position.

## EMERGENCY STOP

To abort the 2050 or 2055 press during welding, simply press the red EMERGENCY STOP button located at the front center of the press base.

Once the EMERGENCY STOP button has been depressed, the head will retract and return to its “home” position. Simply rotate the EMERGENCY STOP button clockwise 1/4 turn to release the press for further operation.



# FINE ADJUSTMENTS



**NOTE:** Consult the Applications Manual or call our Applications Lab for proper booster selection.



## WARNING

High gain boosters, such as silver and black in combination with high gain horns can result in the horn cracking or failing.

## BOOSTER SELECTION

The first step in optimizing welding conditions is to select a booster which will provide the necessary amplitude. For parts one inch (25.4mm) in diameter or greater, start with a moderately high amplitude booster such as a gold. For smaller parts, start with a green booster. Determine optimum amplitude by welding a few parts, and repeat the procedure with boosters giving higher or lower amplitude. If there appears to be little or no difference, use the booster giving the highest amplitude.

Seven standard boosters, color coded or engraved for ease of identification, are available either to increase or decrease the amplitude.

### BOOSTER

Color	O-Ring Mount (standard) Part No.	Rigid Mount (optional) Part No.	Gain	Amplitude Effect
Black	BHN15TBK	BHNR15BK	2.50	Increase
Silver	BHN15TSI	BHNR15SI	2.00	Increase
Gold	BHN15GD	BHNR15GD	1.50	Increase
Brown	BHN15BR	BHNR15BR	1.25	Increase
Green	BHN15GR	BHNR15GR	0	No Change
Purple	BHN15PU	BHNR15PU	0.75	Decrease
Blue	BHN15BU	BHNR15BU	0.50	Decrease

## PRESSURE

During the welding process, sufficient pressure should be applied to the part so that the mating surfaces contact each other. If the pressure is too low, the process will run inefficiently causing unnecessarily long weld time cycles, marking of the parts or poor welding. If the pressure is too high, the horn may stop vibrating, the part(s) might fracture, or the power supply might overload.



**NOTE:** Contact between the booster and horn should be parallel. When encountering symptoms such as loud noises or tuning difficulties, examine the booster / horn interfaces for parallelism, corrosion, galling or foreign deposits. Also check the integrity and tightness of the stud.



**WARNING**

*DO NOT use anything coarser than 400 grit emery cloth.*



**WARNING**

*Machining of booster / horn may alter the ability to tune the component to the system. System inoperation may occur.*

## **RE-ESTABLISHING PROPER BOOSTER / HORN INTERFACES**

To re-establish proper interfaces, follow these instructions:

1. Using open-ended wrenches, separate the booster from the horn. Clean each item and then examine interfaces for irregularities (scoring).
2. If irregularities are present, remove the stud.
3. Tape a sheet of 400 grit emery cloth to a smooth, flat surface. (Do not use coarser than 400 grit.)
4. Grasp the lower portion of the booster or horn and move it across the emery cloth. To ensure proper lapping, a) hold the part straight, b) apply light downward pressure, and c) move in one direction only in a figure 8 pattern.

Repeat the figure 8 pattern once more.

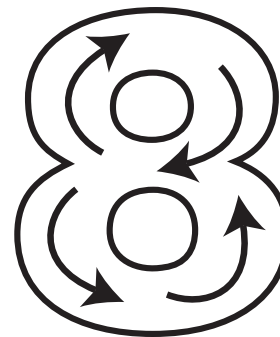

5. Then, rotate the booster or horn 1/3 of a turn in a clockwise direction and then repeat step 4.
6. Repeat step 5.
7. Using wire brush, clean stud, then replace securely. Tighten new stud to the recommended torque specifications on page 15.



# MAINTENANCE

---



**NOTE:** If packing unit for return shipment, **DO NOT** use styrofoam “peanuts.”

## **REPAIRS / SERVICE**

If problems are encountered, contact our Service Department as follows:

Phone: 1-800-745-1105 • 1-203-270-4600 ext. 343 or 366

Fax: 1-203-270-4610

E-Mail: [service@sonics.biz](mailto:service@sonics.biz)

It is suggested that a system in need of repair be sent back to the factory, with a written description pertaining to the nature of the problem.

**Always contact the factory for return authorization** before shipping any instrument. Include date of purchase, model number, and serial number. For units not covered by the warranty, a purchase order should be forwarded to avoid unnecessary delay. Care should be exercised to provide adequate packing to insure against possible damage in shipment. The system must be sent with all transportation charges prepaid and return method of shipment indicated.

## **DRAINING THE AIR FILTER BOWL**

Periodically check the Air Filter Bowl for any moisture and/or condensation, and drain as necessary.

**AIR FILTER  
BOWL**



To drain, simply unscrew the knurled brass fitting at the bottom of the bowl. Drain any collected moisture, and then replace the fitting.



## WARNING

*Always disconnect the power supply from the electrical source before removing covers.*



## WARNING

*Do not operate press without covers in place.*

## COVER REMOVAL

### MODEL 2050 COVER REMOVAL

#### *To remove the side panel cover:*

- a. Maintain air pressure and unplug the power supply from the electrical source.
- b. Loosen and remove the 2 Phillips pan head screws on the back of the cover.
- c. Loosen and remove the 2 socket head cap screws at the bottom of the cover.
- d. Loosen column clamps.
- e. Raise head as shown below to bottom of column cap.

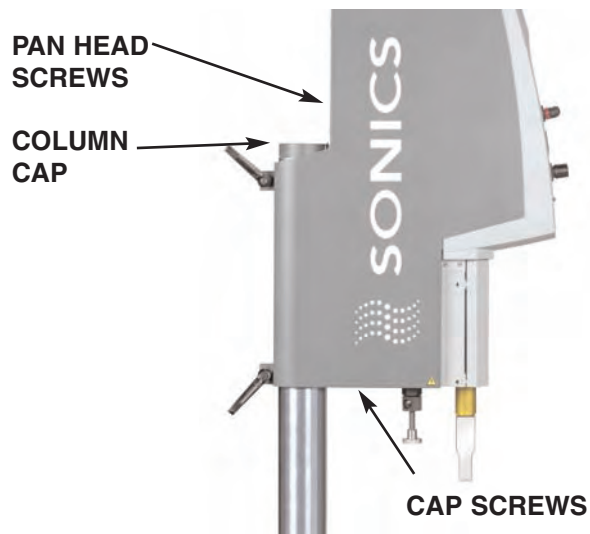

- f. Slide the cover back and then lift it up and off.



**To remove the pinch point cover:**

- a. Loosen and remove the cover's 4 screws - 2 on each side of the cover.

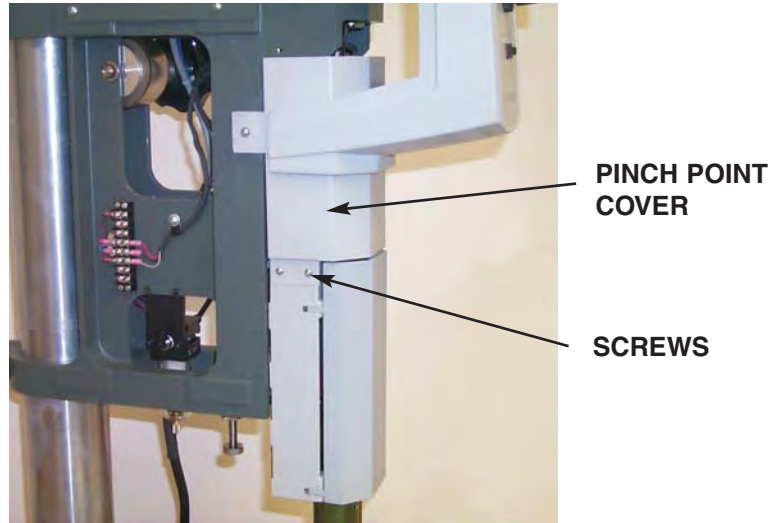

- b. Pull the cover to the front and then pull it down and off as shown below.



**WARNING**

*Always disconnect the power supply from the electrical source before removing covers.*

**MODEL 2055 COVER REMOVAL**

**To remove the side panel cover:**

- a. Maintain air pressure and unplug the power supply from the electrical source.
- b. Loosen and remove the 4 Phillips pan head screws - 2 on the top of the cover and 2 on the bottom. (See photo on the next page.)



**SONICS**



## WARNING

*Do not operate press without covers in place.*



**NOTE:** Pressure switch is factory set and should not be adjusted unless authorized by Sonics Service Department.



## WARNING

*Do not operate press without covers in place.*

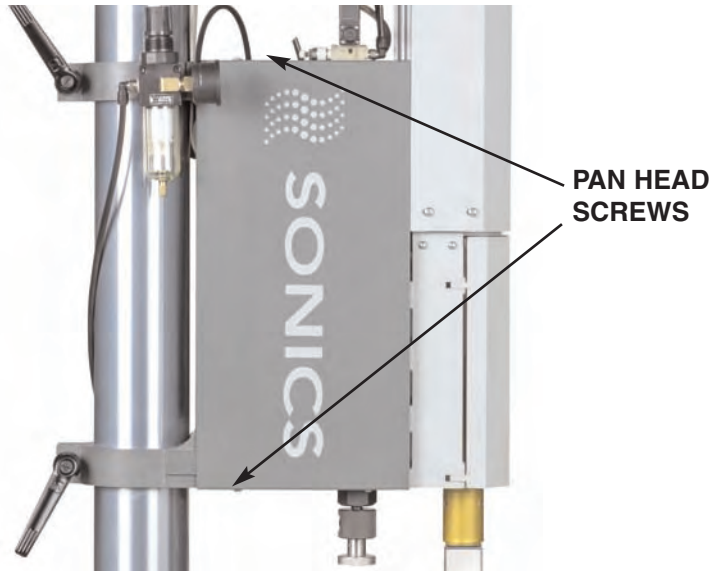

## PRESSURE SWITCH ADJUSTMENT

For systems mounted in the normal vertical position with downward travel, no adjustment should be necessary. The minimum trigger pressure is factory set at 4-7 psig.

However, if the minimum trigger pressure requires recalibration or re-adjustment, the pressure switch can be accessed and adjusted.

To access the pressure switch, it is first necessary to remove both the side panel cover and the pinch point cover as described above (for either the model 2050 or 2055 press). Then, observe the following procedure:

1. Loosen the jam nut holding the 1/4-20 cap screw in place.
2. Rotate the small, knurled, threaded rod upward until the Pressure Switch closes.

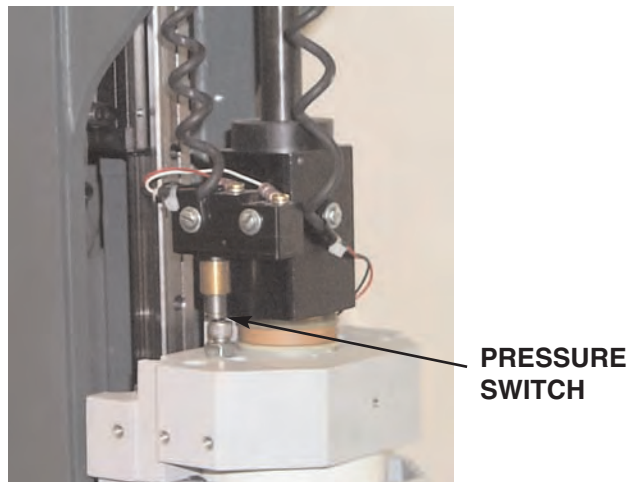

- 
3. Next rotate the cap screw down until the Pressure Switch opens.
  4. Rotate cap screw down one turn past the Pressure Switch open position.
  5. Tighten the jam nut to lock cap screw in position.
  6. Replace pinch point cover and the side panel cover and position securely.
  7. Plug the power supply into the electrical source.
  8. Cycle the welder.

The press is now set to trigger at the minimum trigger pressure of 4-7 psig.

A press actuating in an upward or horizontal direction should be set to trigger at a minimum of 8-10 psig. Lower values may affect trigger performance where false triggering may be observed.



# WARRANTY

---

Sonics & Materials, Inc., hereinafter referred to as "Sonics", warrants its products for a period of one year from the date of original shipment against defects in materials and workmanship under normal installation, use and maintenance as described in the operating instructions which accompany such equipment. During the warranty period, Sonics will, at its option, as the exclusive remedy, either repair or replace without charge for material and labor, the part(s) which prove upon our examination to be defective, provided the defective unit is returned to us properly packed with all transportation charges F.O.B. Sonics dock, Newtown, CT. Warranty period on equipment rentals that are converted to purchase are deemed to have commenced on the date of original rental equipment shipment.

Ultrasonic plastics welding horns constructed of titanium or aluminum are guaranteed against defects for a period of one year from date of shipment. Sonics will repair or replace a cracked or defective horn once without charge, if failure occurs within the warranty period.

Ultrasonic plastics welding horns constructed of steel are guaranteed against defects for a period of ninety days from date of shipment. Sonics will repair or replace a cracked or defective steel horn once at a charge of 50% of the original purchase price, if failure occurs within the warranty period.

Ultrasonic metal welding horns constructed of titanium or steel are guaranteed against defects for a period of one year from date of shipment. Sonics will repair or replace a cracked or defective horn once without charge, if failure occurs within the warranty period.

Sonics warrants its ultrasonic converters for a period of one year from date of shipment with a one-time replacement if a converter proves to be non-repairable.

When customer site service is required, all travel, living and related expenses will be billed at cost. In-warranty service labor time (including travel time) at the customers facility is provided Monday through Friday (excluding holidays) from 8:00 am to 5:00 pm. Any in-warranty service time requested outside of these days and hours will be billed at 150% of Sonics current rate per hour for such site service work.

## ***LIMITATION OF WARRANTY***

This warranty does not apply to items subject to normal wear and tear or, to equipment or tooling which has been subject to unauthorized repair, misuse, abuse, negligence or accident. Misuse includes operation of equipment with tooling that is not qualified for the equipment or tooling not properly installed on the equipment.

Equipment which, in our judgment, shows evidence of having been used in violation of operating instructions, or which has had the serial number altered or removed, will be ineligible for service under this warranty.

For components and parts not manufactured by Sonics but included in Sonics manufactured equipment, this warranty shall be limited to the warranty as given to Sonics by said original component or part manufacturer.

Ultrasonic horns supplied by Sonics are manufactured to exacting specifications and are tuned to vibrate at a specific frequency. Using an out-of-tune horn will cause damage to the equipment and may result in warranty nullification. Sonics assumes no responsibility for converters, horns or fixtures not supplied by Sonics or for consequential damages resulting from their usage.

Ultrasonic converters showing signs of excessive heat or contamination, such as but not limited to, oils and moisture, are not covered by this warranty.

Warranty does not apply to ultrasonic horns quoted as prototype, experimental or of unusual design which, in our judgment are more likely to fail in use.

Warranty does not apply to re-sharpening of ultrasonic blade type cutting or slitting horns.

Warranty does not apply to knurl pattern wear on ultrasonic plastics and metal welding horns and tips.

Warranty does not apply to ultrasonic horn or tip face wear when used with plastics that are molded with fillers, such as but not limited to, glass or talc.

This warranty does not apply to ultrasonic plastics welding equipment, horns or fixtures where metal-to-metal tooling contact time is in excess of 250 milliseconds.

This warranty does not apply to used or re-built equipment.

This warranty is non-transferable.

Data supplied in Sonics instruction manuals has been verified and validated and is believed adequate for the intended use of the equipment. If the equipment or procedures are used for purposes other than those specified herein, confirmation of their validity and suitability should be obtained in writing from Sonics. Otherwise Sonics does not guarantee results and assumes no obligation or liability.

This warranty is in lieu of any other warranties, either express, implied, or statutory. Sonics neither assumes nor authorizes any person to assume for it any other obligation or liability in connection with the sale of its products. Sonics hereby disclaims any warranty or merchantability or fitness for a particular purpose. No person or company is authorized to change, modify, or amend the terms of this warranty in any manner or fashion whatsoever. Under no circumstances shall Sonics be liable to the purchaser or to any other person for any incidental or consequential damages or loss of profit or product resulting from any malfunction or failure of this Sonics product.

# APPENDIX

## 2050 LAYOUT FRONT VIEW

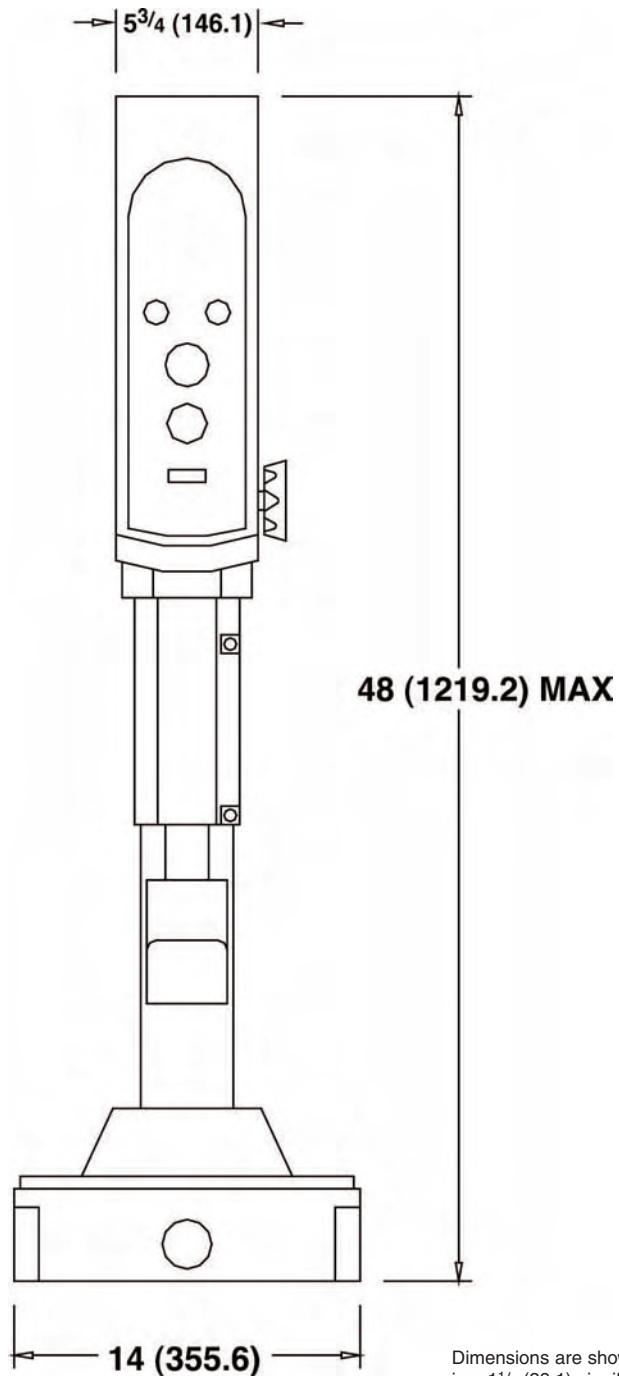

Dimensions are shown in inches and millimeters,  
i.e.,  $1\frac{1}{2}$  (38.1) signifies  $1\frac{1}{2}$ " (38.1mm)

# APPENDIX

## 2050 LAYOUT SIDEVIEW

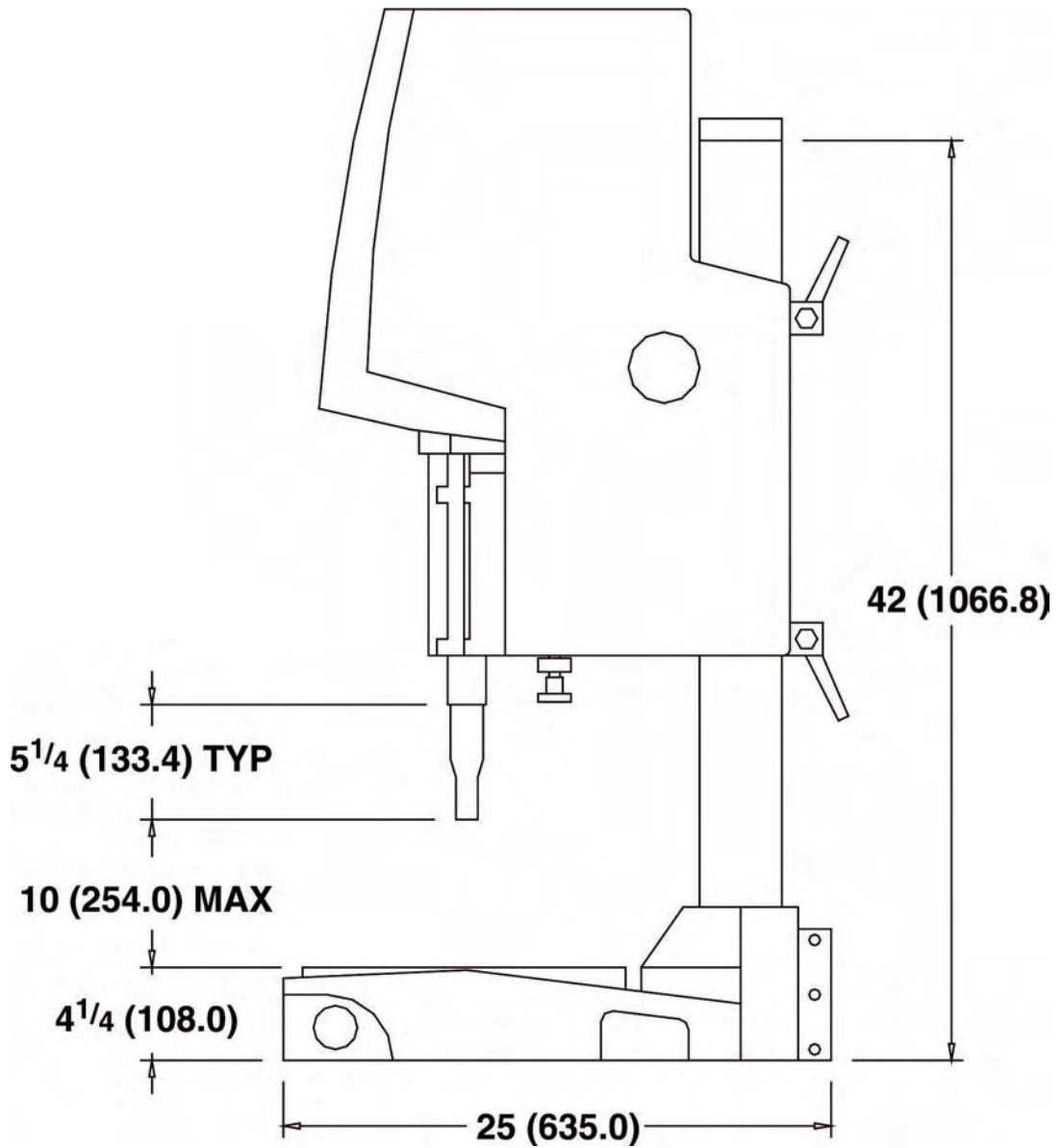

Dimensions are shown in inches and millimeters, i.e., 1 1/2 (38.1) signifies 1 1/2" (38.1mm)

# APPENDIX

## 2050 EXPLODED ASSEMBLY DRAWING

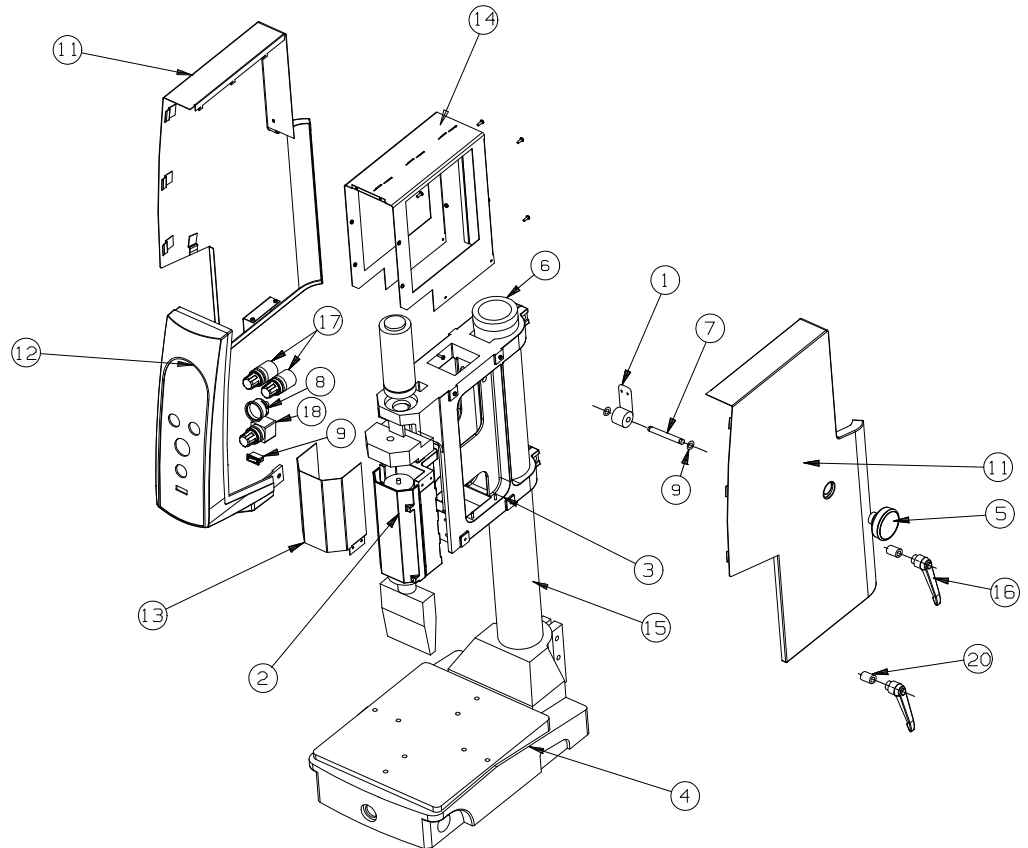

PART NO	ITEM	QTY	DRAWING NO	DESCRIPTION
872-00034	1	1	SMI-2079-27	SPRING TRIPLE ROLL ASSY
301-0211	2	1	SMI-2079-33	CONVERTER CLAMP ASSY
301-0212	3	1	SMI-2079-22	CENTER FRAME ASSY
301-0213	4	1	SMI-2079-3B	BASE ASSY
515-0022	5	1	PURCHASED	KNOB
516-01176Y	6	1	SMI-2079-5	COLUMN CAP
516-0119	7	1	SMI-2079-17	SHAFT, SPLINE 2050
804-00011	8	1	SMI-2079-23	PRESSURE GAUGE
810-00022	9	2	PURCHASED	RETAINING RINGS
	10	1		
818-0309	11	1	SMI-2079-11	PANEL COVER LEFT & RIGHT
818-00310	12	1	SMI-2079-15	BEZEL
818-00317	13	1	SMI-2079-9	CONVERTER SHIELD
818-00318	14	1	SMI-2079-13	FRAME
820-00011	15	1	SMI-2079-4	COLUMN
841-00007	16	2	PURCHASED	HANDLE
857-00003	17	2	SMI-2079-23	FLOW CONTROL
865-00001	18	1	SMI-2079-23	REGULATOR
875-00073	19	1	SMI-2079-23	HEAD DOWN SWITCH
516-0126	20	2	SMI-2079-18	EXTENDER COLUMN CLAMP HANDLE
	21			
	22			

# APPENDIX

## 2055 LAYOUT FRONT VIEW

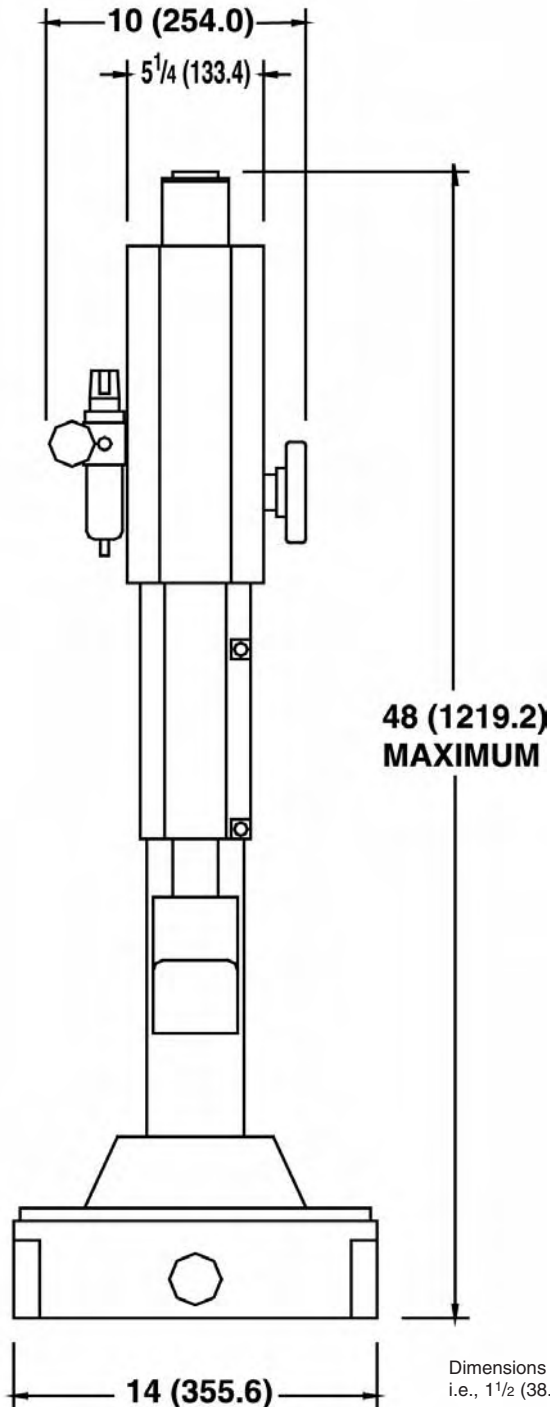

# APPENDIX

## 2055 LAYOUT SIDEVIEW

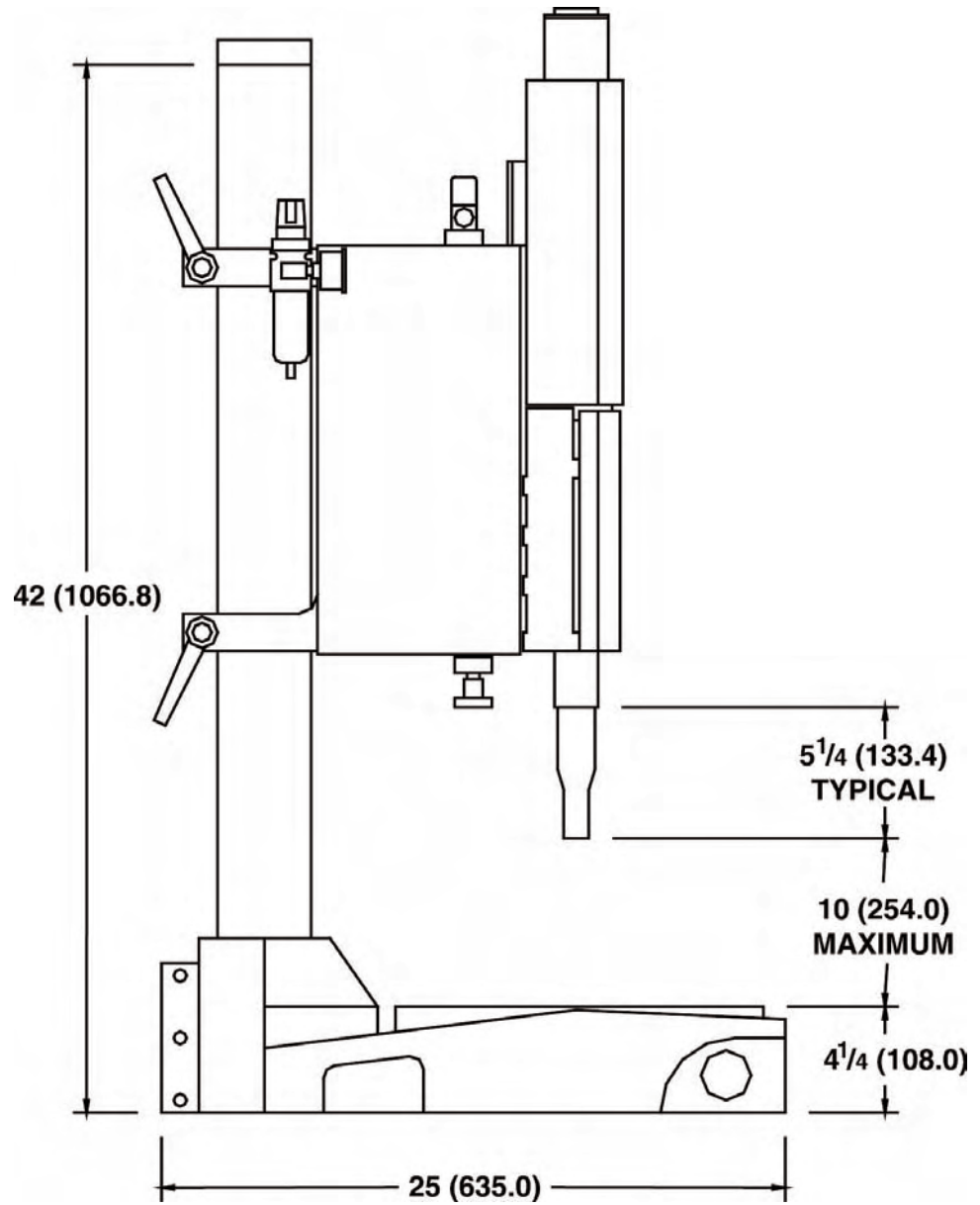

Dimensions are shown in inches and millimeters, i.e., 1 1/2 (38.1) signifies 1 1/2" (38.1mm)

# APPENDIX

## 2055 EXPLODED ASSEMBLY DRAWING

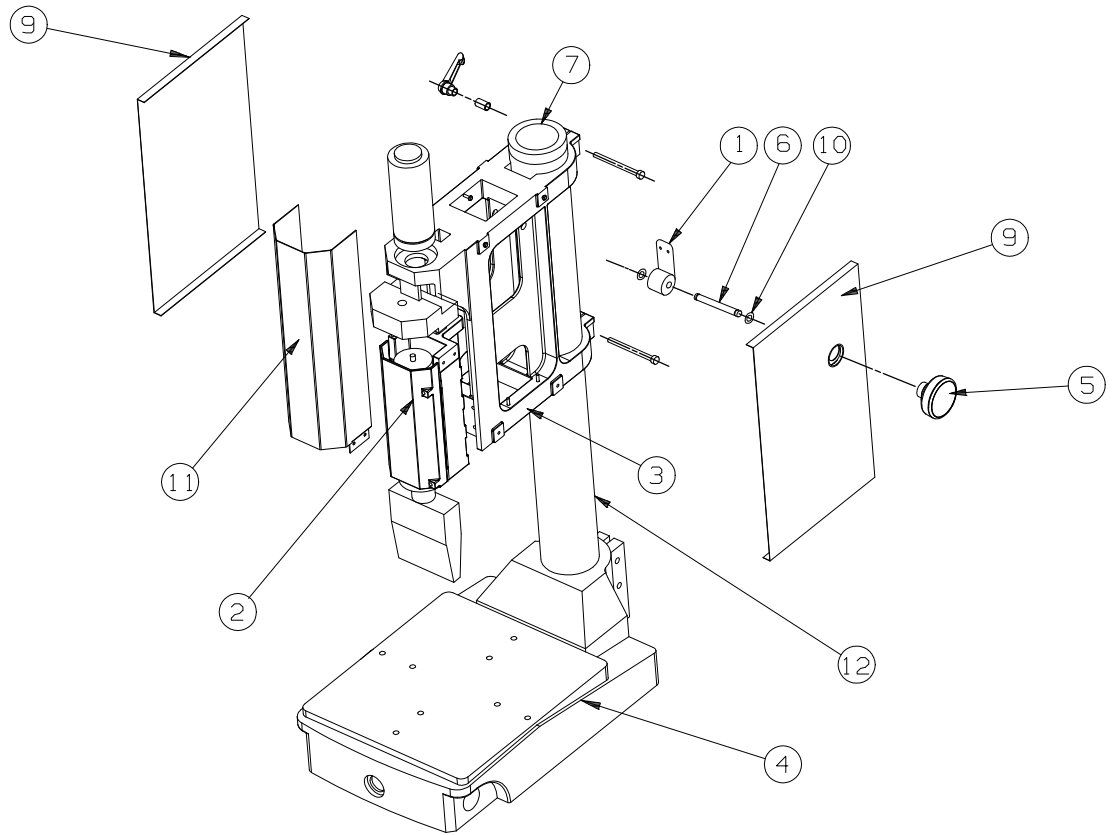

PART NO	ITEM	QTY	DRAWING NO	DESCRIPTION
301-0108	1	1	SMI-1990-36	SPRING DOUBLE ROLL ASSEMBLY
301-0211	2	1	SMI-2079-33	CONVERTER CLAMP ASSEMBLY
301-0222	3	1	SMI-2079-34	CENTER FRAME ASSEMBLY
301-0213	4	1	SMI-2979-3B	BASE ASSEMBLY
515-0022	5	1	PURCHASED	KNOB
516-0127	6	1	SMI-2079-17	SHAFT, SPLINE 2055
516-0117GY	7	1	SMI-2079-5	COLUMN CAP
	8	1		
701-0156GYS	9	1	SMI-2079-10	SIDE COVERS MODEL 2055
810-00022	10	2	PURCHASED	RETAINING RING
818-00315	11	1	SMI-2079-9	FRONT COVER
820-00011	12	1	SMI-2079-4	COLUMN

# APPENDIX

## BASE LAYOUT

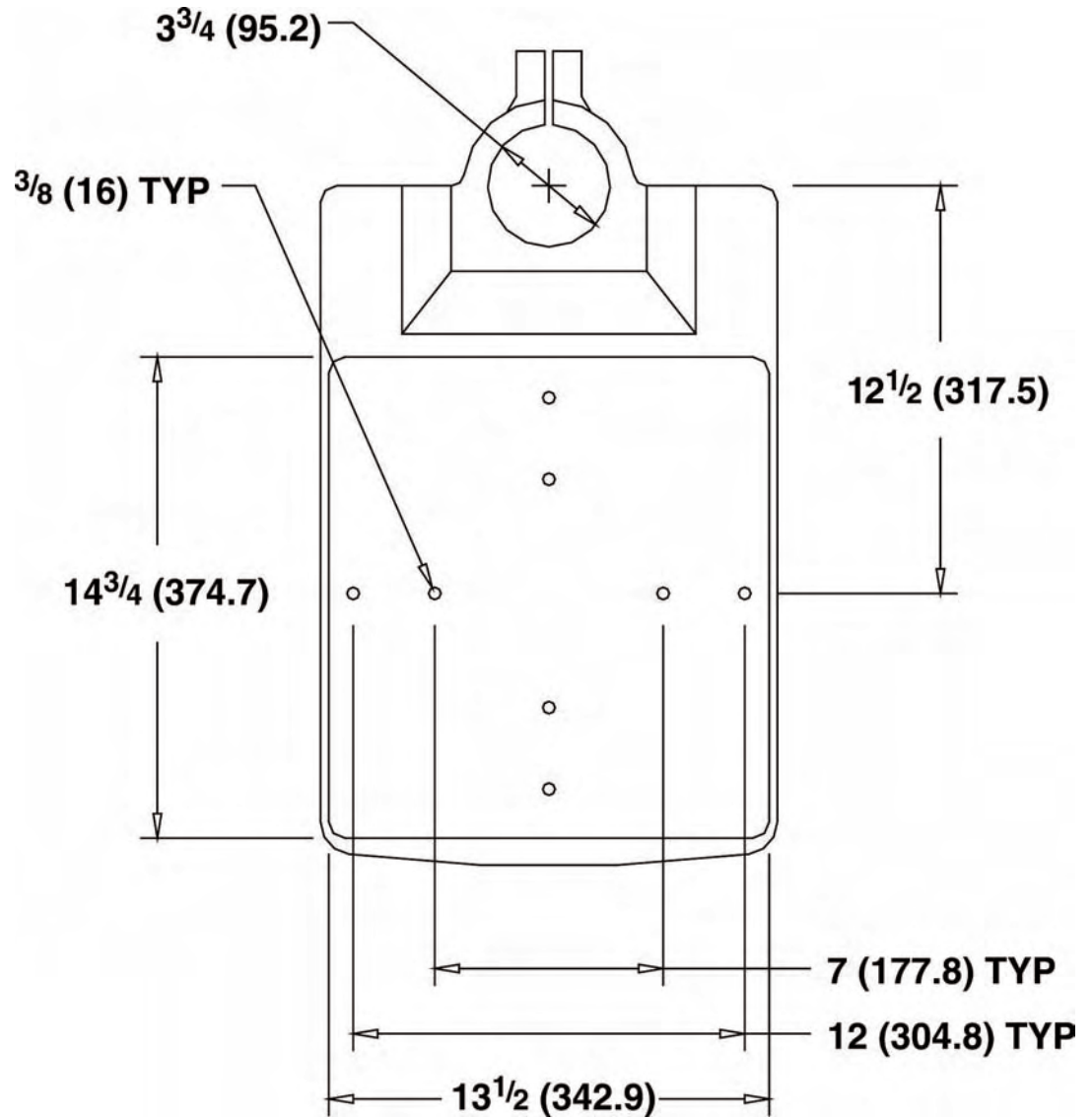

Dimensions are shown in inches and millimeters, i.e.,  $1\frac{1}{2}$  (38.1) signifies  $1\frac{1}{2}$ " (38.1mm)

# APPENDIX

## OPTIONAL STAND-ALONE MOUNTING HUB LAYOUT

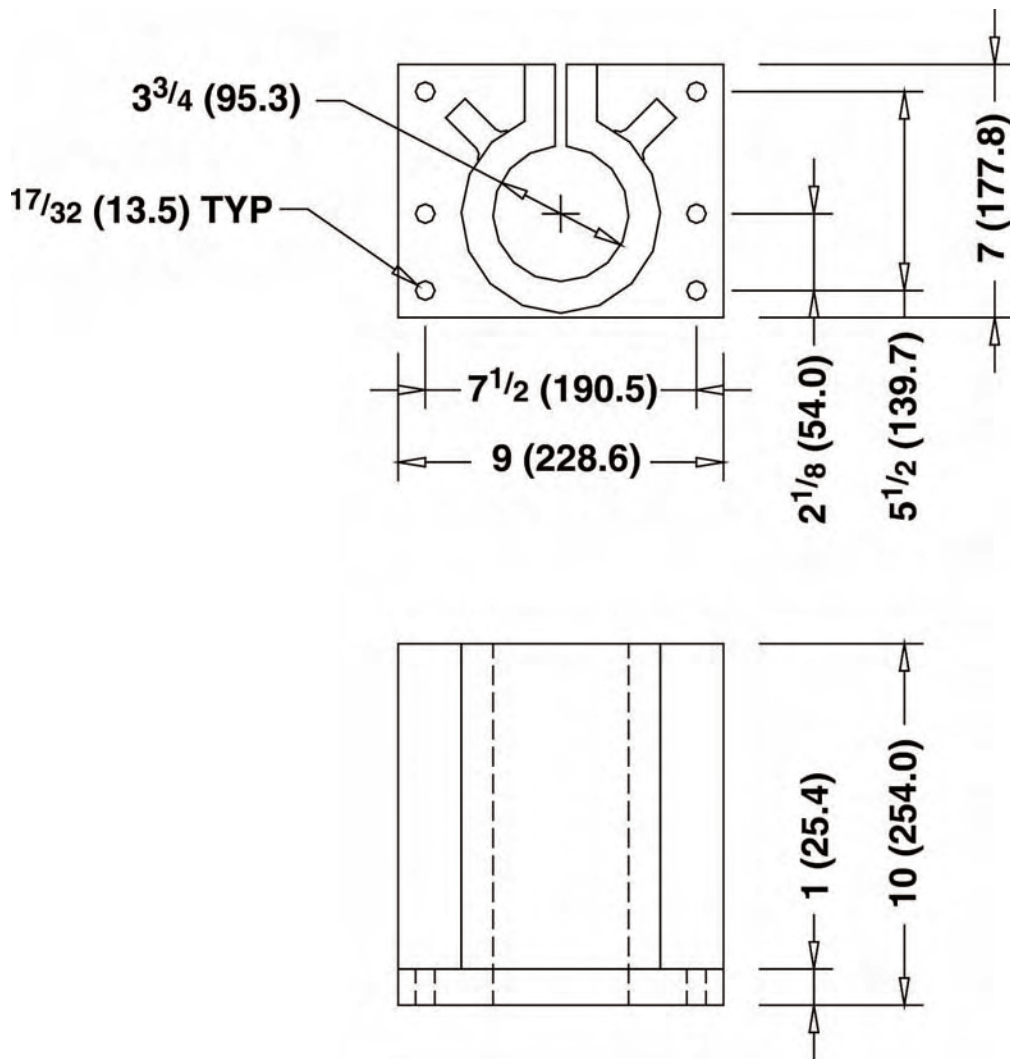

Dimensions are shown in inches and millimeters, i.e.,  $1\frac{1}{2}$  (38.1) signifies  $1\frac{1}{2}$ " (38.1mm)