

# more Power Features

## new FEATURES

- Digital Time and/or Constant Energy Weld Modes Available
- Single-piece Rigid Cast Aluminum Machine Base and Column Hub
- Digital Amplitude Control
- Ultrasonic Horn/Stack Frequency Display
- Front Panel Pneumatic and Microprocessor Controls

## new MODELS

### WELD BY:

digital time

- **Model XPT 1200** (1200 watts)
- **Model XPT 2200** (2200 watts)

digital time and/or constant energy

- **Model XPE 1200** (1200 watts)
- **Model XPE 2200** (2200 watts)

### STANDARD FEATURES INCLUDE:

- Automatic Frequency Tuning
- Weld, Hold, Delay and Afterburst Timers
- Back-Lit LCD Display
- Ultrasonics Load Meter Scale
- Upper and Lower Weld Limit Settings
- Soft-start Overload Protection Circuitry
- Load Regulation Circuitry
- Digital Wattage Display



**SONICS**<sup>®</sup>  
SONICS & MATERIALS, INC.



## Models XPT and XPE Integrated Welder For Ultrasonic Plastics Assembly



# X-Press

Leaders in the field of ultrasonic plastics welding equipment and technology since 1969, Sonics & Materials introduces its new 20 kHz X-Press integrated welder, an all-in-one super-rigid ultrasonic press that combines power, versatility and microprocessor control in one convenient unit.

The X-Press easily handles significantly larger part size and force requirements and delivers consistent reliability for every application. The built-in microprocessor with easy-access front-panel keypad provides streamlined smart-logic navigation through user-friendly welding mode controls and displays.

## dimensional data:

All Dimensions: Inches (mm)

## X-Press features

- Single Piece Rigid Cast Aluminum Machine Base and Column Hub
- Super-rigid 3.75" Steel Column Diameter with 0.5" Wall Thickness
- Single Rail Linear Slide
- Direct In-Line Air Cylinder
- Front Panel Pneumatic Speed and Pressure Controls
- Microprocessor with Front Panel Keypad

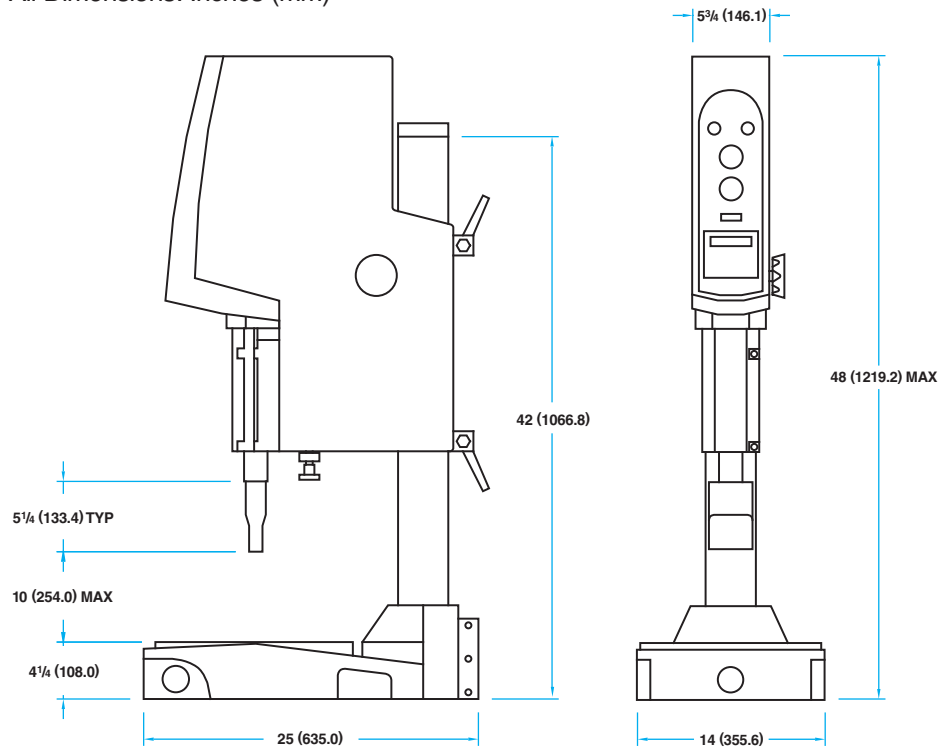

## specifications, additional features, and options

Dual Cycle Start Buttons	Standard
Non-Contact Cycle Start Buttons	Optional
Front Emergency Stop	Standard
Head Adjust Counterbalance Spring	Standard
Adjustable Positive Stop	Standard
Automation Limit Switches	Optional
360° Snap-In Stack Assembly	Standard
Rigid Mount Booster	Optional
Stand Alone Column Hub	Optional
Extended Length Column	Optional
4" (101.6) Stroke Air Cylinder	Standard
Air Cylinder Bore Diameter	2.5" (63.5)
Clamping Force at 90 PSIG	441 lbs. (1961n)
Input Voltage	220 VAC
optional for 1200 watts	120 VAC
Weight	180.5 lbs. / 81.9 kg

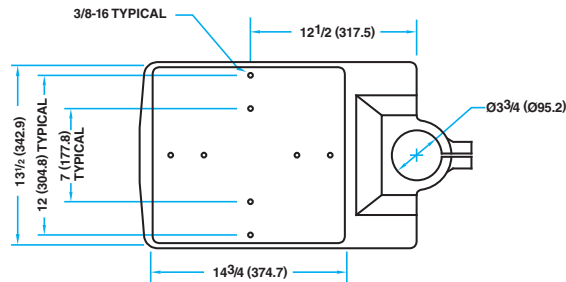

### OPTIONAL STAND-ALONE HUB

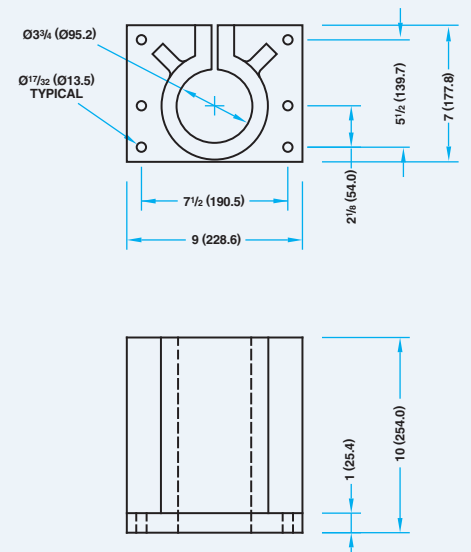

Sonics & Materials, Inc.

Registered by UL to ISO 9001